

Installation / Operator / Maintenance Manual for Stromboli & Lascar

Manufactured by:



**Frohnhof 9
91580 Petersaurach
Germany
T: ++49 9802 951473
F: ++ 49 9802 9589909
www.wolf-bavaria.com**

Imported by:



**PO Box 120
Pound Ridge, NY
T: 914 764 5679
F: 614 764 0465
www.wittus.com**



Installation / Operator / Maintenance Manual

LASCAR

Model#: 0601 (Soap Stone)
Model#: 0602 (Tiles)



STROMBOLI

Model#: 0700 (Steel)
Model#: 0701 (Soap Stone)
Model#: 0702 (Tiles)



IMPORTANT!

CAUTION: Please read this entire manual before you install and use your new room heater. For your safety, follow these installation, operation and maintenance instructions exactly, without deviation. Failure to follow these instructions may result in property damage, bodily injury, or even death. If this appliance is not properly installed, a house fire may result. Contact your local building or fire officials about restrictions and installation inspection requirements in your area.

1. If using an older chimney, it must be inspected for adequate serviceability. Refer to *Chimney Inspection* on page 11 of this manual.
2. The minimum clearances must be maintained for all combustible surfaces and materials, including furniture, carpet, drapes, clothing, wood, papers, etc. Do not store firewood within this clearance space. Failure to maintain clearances to all combustible materials may result in a house fire.
3. This appliance requires non-combustible floor protection as outlined in this manual (see *Floor Protection* on page 8 for additional information).
4. Minimum ceiling height must be 7 feet (213 cm) (measured from base of appliance to ceiling).
5. **DO NOT CONNECT THIS UNIT TO A CHIMNEY FLUE THAT IS CONNECTED TO ANOTHER APPLIANCE.**
6. Do not connect this appliance to air ducts or any air distribution system.
7. **PREVENT CREOSOTE FIRE:** Inspect and clean chimney frequently. Under certain conditions of use, creosote build-up can occur rapidly. Inspect chimney connector and chimney twice monthly and clean if necessary. Using green or inadequately seasoned wood can greatly increase creosote build-up. Use dry wood only to minimize creosote build-up.
8. **USE SOLID WOOD FUEL ONLY:** This appliance is approved for burning dry, seasoned, natural wood only. **CAUTION: BURN UNTREATED WOOD ONLY. DO NOT BURN GARBAGE OR FLAMMABLE FLUIDS SUCH AS GASOLINE, NAPHTHA OR ENGINE OIL.**
9. Never use gasoline, gasoline-type lantern fuel, kerosene, charcoal lighter fluid, or similar liquids to start or “freshen up” a fire in this heater. Keep all such liquids well away from heater while it is in use.
10. **DO NOT OVERFIRE:** If heater or chimney connector glows, you are overfiring. Overfiring this appliance could cause a house fire. Overfiring is a condition where the appliance is operated at temperatures above its design capabilities. Overfiring can be caused by improper installation, improper operation, lack of maintenance or improper fuel usage. Damage caused from overfiring is NOT covered under the manufacturer’s limited warranty.
11. **NEVER LEAVE AN UNATTENDED STOVE BURNING ON HIGH.** Operation of the stove with the primary air control at its highest burn rate setting for extended periods can cause dangerous overfiring conditions. The primary air control should only be positioned at the highest setting during start-up procedures and for short durations. When leaving the stove unattended, ensure that the primary air control is set to the low or medium low range.
12. Use the metal ash drawer only to dispose of ashes.
13. **IN THE EVENT OF A COMPONENT FAILURE, USE ONLY COMPONENTS PROVIDED BY THE MANUFACTURER AS REPLACEMENT PARTS.**
14. Burning any kind of fuel uses oxygen from the dwelling. Be sure that you allow an adequate source of fresh air into the room where the stove is operating (see *Ventilation and Outside Air* on page 9).
15. **CAUTION: HOT WHILE IN OPERATION.** An appliance hot enough to warm your home can severely burn anyone touching it. Keep children, clothing and furniture away. Contact may cause skin burns. Do not let children touch the appliance. Train them to stay a safe distance from the unit.
16. Do not operate this appliance without the firebox baffle brick properly installed.
17. Build fires directly upon the brick hearth inside the stove. Do not use grates, irons or any other method to elevate the fire.
18. **SAVE THESE INSTRUCTIONS.**
19. See the listing label located on the back of stove (or see Safety/Listing Label on page 24).
20. It is highly recommended to install a smoke detector in the home when installing a wood stove.



Congratulations on the purchase of your new woodstove manufactured by Wolf Bavaria made in Germany.

When you purchased your new woodstove, you joined the ranks of thousands of concerned individuals whose answer to their home heating needs reflects their concern for aesthetics, efficiency and our environment. We extend our continued support to help you achieve the maximum benefit and enjoyment available from your new German wood stove. It is our goal at Wolf Bavaria to provide you, our valued customer, with an appliance that will ensure you years of trouble-free warmth and pleasure.

Thank you for selecting a Wolf Bavaria Products stove as the answer to your home heating needs.

Sincerely,
All of us at Wolf Bavaria



TABLE OF CONTENTS

1.	Planning Your Installation	7
1.1	Questions to Ask Local Building Officials	7
1.2	Smoke Detectors	7
1.3	Selecting a Location	7
1.4	Clearance from Combustible Walls	8
1.5	Floor Protection	9
1.6	Ventilation	10
1.7	Fresh Air	10
2.	Installation	11
2.1	Installing Marble Accents	11
2.2	Baffle Bricks	11
2.3	Types of Chimneys	12
2.4	Acceptable Connector Pipe for Installations	12
2.5	Chimney Inspection	12
2.6	Chimney Height Requirements	13
2.7	Draft Requirements	13
2.8	Combustible Wall Chimney Connector Pass-Throughs	15
3.	User's Guide	16
3.1	Hand Protection	16
3.2	Technical Data and Dimensions	16
3.3	Delivery	17
3.4	Unpacking	18
3.5	Acceptable Fuel	18
4.	Safety (Please read, very important!!!)	18
5.	Fresh Air Supply	19
6.	Operating Your Woodstove	19
6.1	Regulating the Heat	19
6.2	Door	20
6.3	Ash Drawer	20
7.	Heating Operation	20
7.1	First Use	20
7.2	Starting a Fire	21
7.3	Environmentally Safe Heating	21
7.4	Adding Wood	21
7.5	Maximum Fuel Supply	21
7.6	Putting the Fire Out	21
7.7	Heating During Transition Periods	22
8.	Cleaning and Maintenance	22
8.1	Door Gasket Seal	22
8.2	Cleaning the Woodstove	22
9.	Troubleshooting	23
9.1	Poor Draft Conditions	23

9.2	Woodstove does not give off enough heat	23
9.3	Woodstove gives off too much heat	23
10.	Important	23
11.	Fire Safety (Please read, very important!!!)	23
12.	Warranty	23
13.	Replacement Parts List	24
13.1	Replacement Tiles	24
13.2	Replacement Glas and Door Handle	24
13.3	Replacement Baffel Bricks	25

Testing/Listing

Appliance Type: Solid Fuel Room Heater

U.S. Test Standard: UL 1482

Canadian Test Standard: CAN/ULC-S627

EPA Exemption Certification

Packaging List

One – Installation and operation instruction manual

One – Warranty

One – Set of Baffle Bricks

One – Set of Tiles or Soap Stone

One – Glove

One – Lever for the Secondary Air

Using this Manual

Please read and carefully follow all of the instructions found in this manual. Please pay special attention to the safety instructions provided in this manual. The Homeowner's Care and Operation Instructions included here will assure that you have many years of dependable and enjoyable service from your appliance.



1. Planning Your Installation

1.1 Questions to Ask Local Building Officials

A correct installation is critical and imperative for reducing fire hazards and perilous conditions that can arise when wood burning appliances are improperly installed. The installer must follow all of the manufacture's instructions.

The installation of a wood burning appliance must conform to local codes and applicable state and federal requirements. Familiarity with these requirements before installation is essential. Important considerations to discuss with local building officials include:

1. Local restrictions?
2. Is a permit required – cost?
(You may wish to contact your insurance company to ask if they require this).
4. Is outside combustion air required?
5. Rooms where the installation is not allowed?

1.2 Smoke Detectors

Since there are always several potential sources of fire in any home, we recommend installing smoke detectors. If possible, install the smoke detector in a hallway adjacent to the room (to reduce the possibility of occasional false activation from the heat produced by the stove). If your local code requires that a smoke detector be installed within the same room, you must follow the requirements of your local code. Check with your local building department in your area.

Note – This appliance is NOT approved for installation into a Manufactured (Mobile) Home.

1.3 Selecting a Location

The design of your home and where you place your stove will determine its value as a source of heat. A wood stove depends primarily on air circulation (convection) to disperse its heat. Therefore, a central location is often best. There are other practical considerations, which must be considered before a final selection of location is made.

- ? Existing Chimneys
- ? Wood Storage
- ? Aesthetic Considerations
- ? Roof Design (Rafter Locations & Roof Pitch)
- ? Room Traffic
- ? Proximity to Combustibles
- ? Electrical Wiring

The installation of this stove will require some research. Once your options are determined, consult with your local building department as to the necessary installation requirements for your area (Is a building permit required, Rooms where installation may not be allowed, etc.).

Warning: Check all local building and safety codes before installation. The installation instructions and appropriate code requirements must be followed exactly and without compromise. Alterations to the stove are not allowed. Do not connect the stove to a chimney system serving another stove, appliance, or any air distribution duct. Failure to follow these instructions will void the manufacture's warranty.

If you plan to vent your stove into an existing masonry chimney, have it inspected by a local fire marshal or qualified installer. Remember that a stove's performance is heavily influenced by the chimney and its location on the roof. An oversized flue may not provide effective draw, and a flue liner may be required (see *Draft Requirements*, page 12). Consult your dealer or qualified installer before final selection is made.

This stove requires pre-installation, including the preparation of the floor and appropriate hearth pad for acceptance of outside air (if applicable), and modifications for flue and chimney.



1.4 Clearance from Combustible Walls

WARNING: IT IS VERY IMPORTANT THAT YOU OBSERVE THE MINIMUM CLEARANCES.

There are listed clearance for your stove which were determined in a Laboratory test, using various “classes” of stove pipe or chimney. Minimums are first established for the stove itself and then increased, based on how much heat is transferred by each class of pipe.

Residential Standard (not approved for manufactured [mobile] homes)

Using single wall pipe connector to the top of the stove.

Clearances USA (inches / millimeters)

A:	10 / 255	C:	18 / 460	E:	18 / 460
B:	12 / 305	D:	11 / 280		

Clearances Canada (inches / millimeters)

A:	21 / 535	C:	27 / 685	E:	27 / 685
B:	21 / 535	D:	20 / 510		

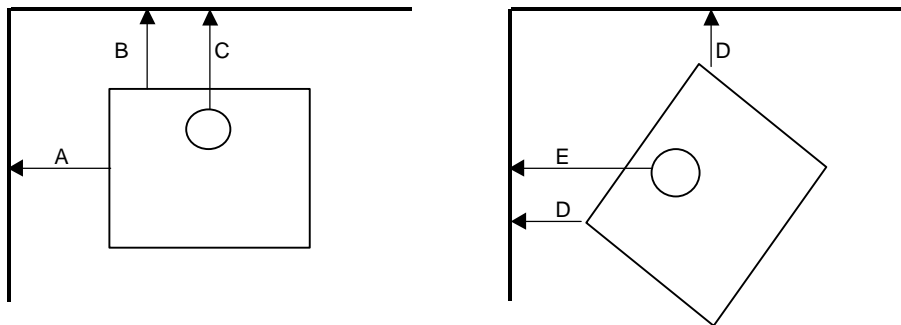

The minimum clearance from the stove front is 52 inch/ 1320mm for both Canada and US.
This dimension must be used by a rotatable (360°) Stove!

PROTECTED WALL CLEARANCE when the stove is installed adjacent to a protected wall system, the variance must be approved by your local building official. Normally, the protected wall system is defined as a non-combustible material with a minimum of 1” air space behind. Check your local building codes or consult a qualified installer (Ref. NFPA 211).

1.5 Floor Protection

This appliance requires a non-combustible floor protection to protect against burning embers. If the floor is to be stone, tile, brick, etc., it must be mortared or grouted to form a continuous, non-combustible surface. If a chimney connector extends horizontally over the floor, protection must cover the floor under the connector and at least 2" (51 mm) to either side. The floor protection must extend completely beneath the stove and to the front, sides, and rear as indicated.

USA REQUIREMENTS

- 16" minimum to the front of the fuel door glass
- 8" (203 mm) minimum beyond the sides of the fuel door opening
- 0" minimum to the back of the stove body

CANADA REQUIREMENTS

- 18" (457 mm) minimum to the front of the fuel door glass
- 8" (203 mm) minimum beyond the sides of the fuel door opening
- 8" (203 mm) minimum to the back of the stove body

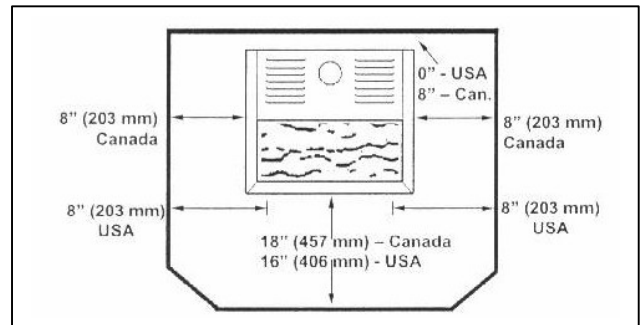

A floor protector must be installed with an R-value of 1.0 (English units). Use of a listed floor protector is acceptable.

An easy means of determining if a proposed alternate floor protector meets these requirements is to follow this procedure:

- 1) Convert specification to R-value:
 - i R-value is given - no conversion is needed.
 - ii k-factor is given with a required thickness (T) in inches: $R = 1/k \times T$
 - iii C-factor is given: $R = 1/C$
- 2) Determine the R-value of the proposed alternate floor protector.
 - i Use the formula in step (1) to convert values not expressed as "R".
 - ii For multiple layers, add R-values of each layer to determine the overall R-value.
- 3) If the overall R-value of the system is greater than the R-value of the specified floor protector, the alternate is acceptable.

Definitions:

$$\text{Thermal conductance} = C = \frac{\text{Btu}}{(\text{hr})(\text{ft}^2)(\text{°F})} = \frac{\text{W}}{(\text{m}^2)(\text{°K})}$$

$$\text{Thermal conductivity} = k = \frac{-(\text{Btu})(\text{inch})}{(\text{hr})(\text{ft}^2)(\text{°F})} = \frac{\text{W}}{(\text{m})(\text{°K})} = \frac{\text{Btu}}{(\text{hr})(\text{ft})(\text{°F})}$$

$$\text{Thermal resistance} = R = \frac{-(\text{ft}^2)(\text{hr})(\text{°F})}{\text{Btu}} = \frac{(\text{m}^2)(\text{°K})}{\text{W}}$$

The Stromboli and Lascar does need additional floor protection. You hat to use 1/2" mill-board, which is equivalent to an R-value of 1.

1.6 Ventilation

(Residential homes which do not require an outside air inlet). Ventilation is essential when using a solid fuel stove. The combustion process uses oxygen from inside the home, and it may be necessary to open a window or install a vent to provide combustion air in a house that is well insulated.

1.7 Fresh Air

In all manufactured homes and in many site-built residences (subject to local code), a stove may be required to use outside air for combustion.

The possible effects of room air starvation, icing, exhaust fans, etc. and the need for adequate ventilation.

The following is not mandatory, but may be included for information. Provision for outside combustion air may be necessary to ensure that fuel-burning appliances do not discharge products of combustion into the house. Guidelines to determine the need for additional combustion air may not be adequate for every situation. If in doubt, it is advisable to provide additional air.

- a) Outside combustion air may be required if:
 1. The solid-fuel-fired appliance does not draw steadily, smoke rollout occurs, fuel burns poorly, or back-drafts occur whether or not there is combustion present.
 2. Existing fuel-fired equipment in the house, such as fireplaces or other heating appliances, smell, do not operate properly, suffer smoke roll-out when opened, or back-draft whether or not there is combustion present.
 3. Opening a window slightly on a calm (windless) day alleviates any of the above symptoms.
 4. The house is equipped with a well-sealed vapor barrier and tight fitting windows and/or has any powered devices that exhaust house air.
 5. There is excessive condensation on windows in the winter.
 6. A ventilation system is installed in the house.
- b) If these or other indications suggest that infiltration air is inadequate, additional combustion air should be provided from the outdoors. Outside combustion air can be provided to the appliance by the following means:
 1. Direct connection: appliances can only use direct connection of outside combustion air if they are certified for the type of installation. Installations shall comply with the manufacturer's instructions.
 2. Indirect method: for an appliance not certified for direct connection of outside combustion air, the outside air is ducted to a point no closer than (12 in.) 300 mm from the appliance, to avoid affecting the performance of the appliance.
 3. A mechanical ventilation system: if the house has ventilation system (air change or heat recovery):
 - a. The ventilation system may be able to provide sufficient combustion make-up air for the solid-fuel-fired appliance.
 - b. The householder should be informed that the ventilation system might need to be re-balanced by a ventilation technician after installation of the appliance.

NOTE: Because the base sits 1" (25.4 mm) off the floor, the outside air floor duct can be positioned along the front to rear center line under the pedestal, but as close to the opening in the base as location permits. The outside air floor duct opening must be protected from any possible obstruction including loose floor insulation.



2. Installation

2.1 Installing Marble Accents

Marble is a natural product, and, therefore, each piece will have its own unique character. Marble can be scratched so care should be taken to avoid putting heavy or rough objects (trivet/steamers) on the surface. If the marble should become scratched, the scratch may be removed or diminished by polishing it with jeweler's rouge (which can be purchased at many hardware stores). Do not install the marble before curing the paint.

The marble set consists of 2 pieces. A large piece which fits onto the stove top and a smaller piece which fits onto the ash lip which is located below the fuel door.

Install the marble gasket and marble as follows:

1. Install gasket on stove top as shown in the illustration. The ceramic fiber blanket and strips (cerawool) which come with each unit must be placed under the marble to insulate it from high temperatures on top of the firebox. Do not place the marble directly on the top metal surface of the stove or it will crack.
2. Place top marble piece onto the gasket on stove top
3. Place ash lip marble into recessed area on the stove ash lip (located below the fuel door).

2.2 Baffle Bricks

The baffle bricks are preinstalled by manufacturer.

IMPORTANT: The baffle bricks require periodic inspection and replacement for proper operation. If the baffle bricks are fractured or crumbling, they should be replaced. Do not operate this appliance without the baffle bricks properly installed.

2.3 Types of Chimneys

The chimney is a vital part of your stove installation. A properly built masonry chimney or a properly installed factory built chimney will assure a consistent draft under a variety of weather conditions (a smoking stove is usually caused by a chimney problem). The stove flue size is 6 inches (152 mm) diameter, which is approximately 28 square inches (711 square mm) minimum. The maximum flue size should be no more than three times the cross sectional area, or the size of the stove flue collar. In this case, that would be no larger than a 1 inch (254 mm) diameter stack, or approximately 85 square inches (216 square cm) maximum.

All chimneys must be installed as specified by local building codes and according to the chimney manufacturer instructions (in the case of a factory built chimney). See the chimney manufacturer instructions for exact specifications. Factory built chimneys must comply with UL 103HT or ULC S629.

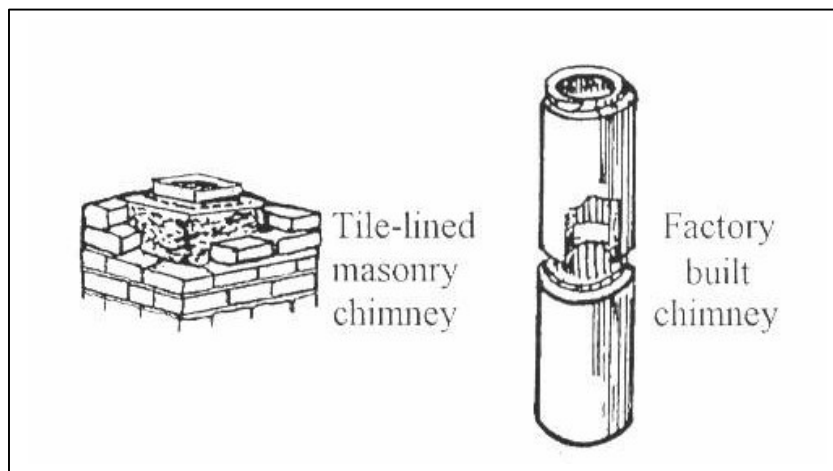

2.4 Acceptable Connector Pipe for Installations

For Standard Residential Clearances: 6" (152 mm) minimum, single wall, 25 gage minimum thickness, stove pipe is acceptable. Three (3) pre-drilled holes are provided in the flue collar for fastening the pipe securely to the stove. Use sheet metal screws for each section when connecting to the manufacturer's transition piece, usually called a dripless connector, to join single wall pipe to their factory built chimney section.

Minimum Flue Size: The required minimum diameter and area required for the flue size is (respectively) 6" / 152 mm diameter, which is approximately 28 square inches / 711 square mm. The maximum flue size should be no more than three times the cross sectional area of the size of the 6" / 152 mm diameter flue collar. In this case, that would be no larger than 10" (254 mm) in diameter (area = approx. 85 sq. inches [216 sq. cm]).

Connection To A Factory Built Chimney: This space heater is to be connected to a factory-built chimney conforming to CAN / ULC – S629, Standard for 650°C Factory-Built Chimneys.

2.5 Chimney Inspection

Existing chimneys must be inspected before installing your stove. Consult your local building department for chimney code requirements. A masonry chimney must have a code approved liner. This liner must not have broken or missing pieces. Some non-code masonry chimneys may be brought up to code by being relined.

(Consult your dealer or qualified chimney sweep). Factory built chimneys should also be inspected, first for creosote deposits (which should be removed), and then for integrity of the stainless steel liner. Look for obvious bulges in the lining which may indicate the need to replace that section (use a bright flashlight). Also, inspect the attic to see that the chimney has proper clearance to combustible framing members. For interior masonry chimneys and most factory built chimneys, this

must be a 2" (51 mm) air space clearance, which must not be filled with insulation or any other material. An exterior masonry chimney must have a 1" (25.4 mm) air space clearance.

Vapor Barrier At Chimney Penetration

Install all venting components per the vent manufacturer's installation instructions. Ensure that there is an effective vapor barrier at the location where the chimney penetrates the exterior of the structure. This can be accomplished by applying a non-hardening, waterproof sealant to the following components:

- ? Around the chimney at the point where the storm collar will meet the chimney just above the flashing.
- ? Along the vertical seam of the chimney pipe, where it is exposed to the weather.
- ? On each nail head on the flashing.
- ? Around the chimney at the point where the storm collar will meet the chimney just above the flashing.

NOTE:

On a flat or tarred and graveled roof, nail and seal the flat roof flashing to the roof on all sides with roofing compound. Do not put screws through the flashing into the chimney pipe.

2.6 Chimney Height Requirements

The chimney must be 3 feet (914 mm) above the level of the roof penetration and a minimum of 2 feet (610 mm) higher than any roof surface within 10 feet (305 cm) (see below). Check with your local building officials for any additional requirements for your area.

Due to prevailing winds, local terrain, adjacent tall trees, a hill or ravine near the home, or adjacent structures, additional chimney height or a special chimney cap may be required to ensure optimum performance.

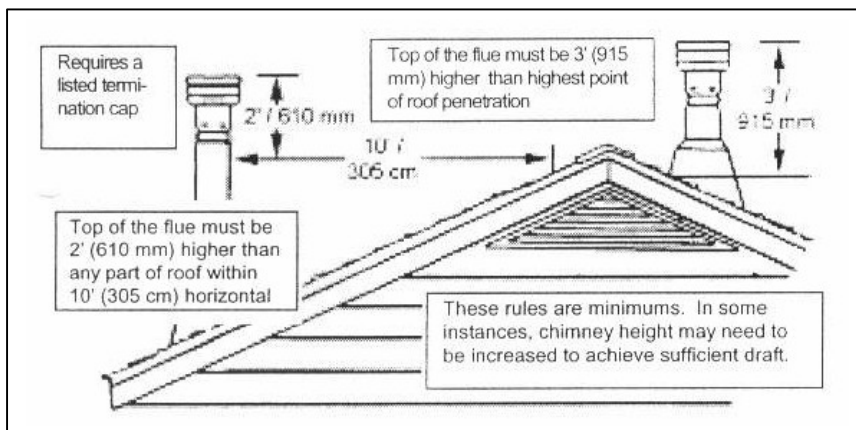

To achieve a stable draft, the total flue height required (from the appliance to termination) is 12 to 15 feet (366 to 457 cm) minimum.

2.7 Draft Requirements

The appliance is merely one component of a larger system. The other equally important component is the venting system. This is necessary for achieving the required flow of combustion air to the forechamber and for safely removing unwanted combustion by products from the appliance. If the venting system's design does not promote these ends, the system may not function properly. A poorly functioning venting system may create performance problems, as well as safety hazard (i.e. an oversized chimney may result in less than optimum performance. Installations into a large, masonry chimney may require a liner to improve performance). A draft test should read greater than .04" W.C. (inches water column) and less than .08" W.C.

American National Standard Institute ANSI/NFPA 211-92, draft 1-7: A chimney or vent shall be so designed and constructed to develop a flow sufficient to completely remove all flue and vent gases to the outside atmosphere. The venting system shall satisfy the draft requirements of the connected appliance in accordance with the manufacturer's instructions.

INSTALLATION

RESIDENTIAL STANDARD
Using 6" (152 mm) Diameter Single Wall Con-
nector Pipe Not Approved For Manufactured
(Mobile) Home

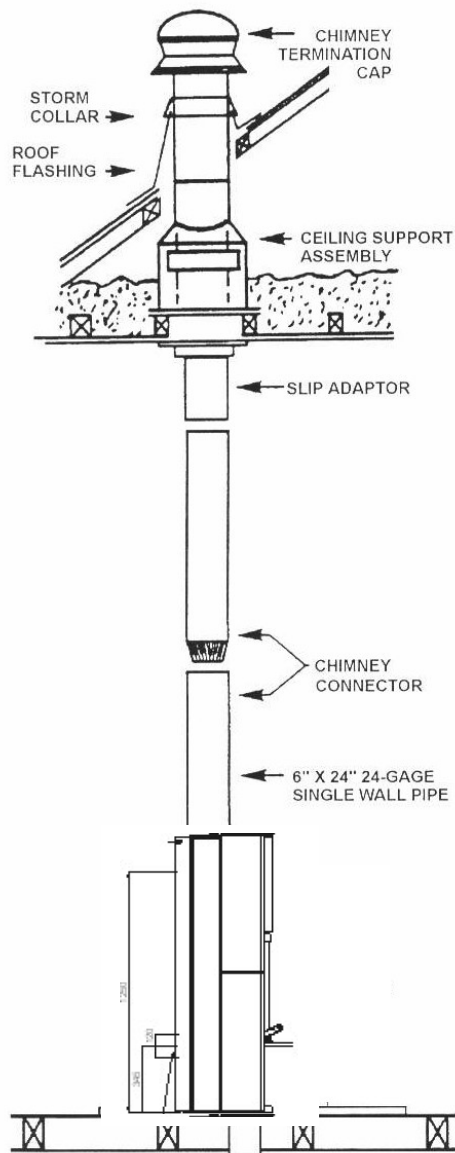

2.8 Combustible Wall Chimney Connector Pass-Throughs

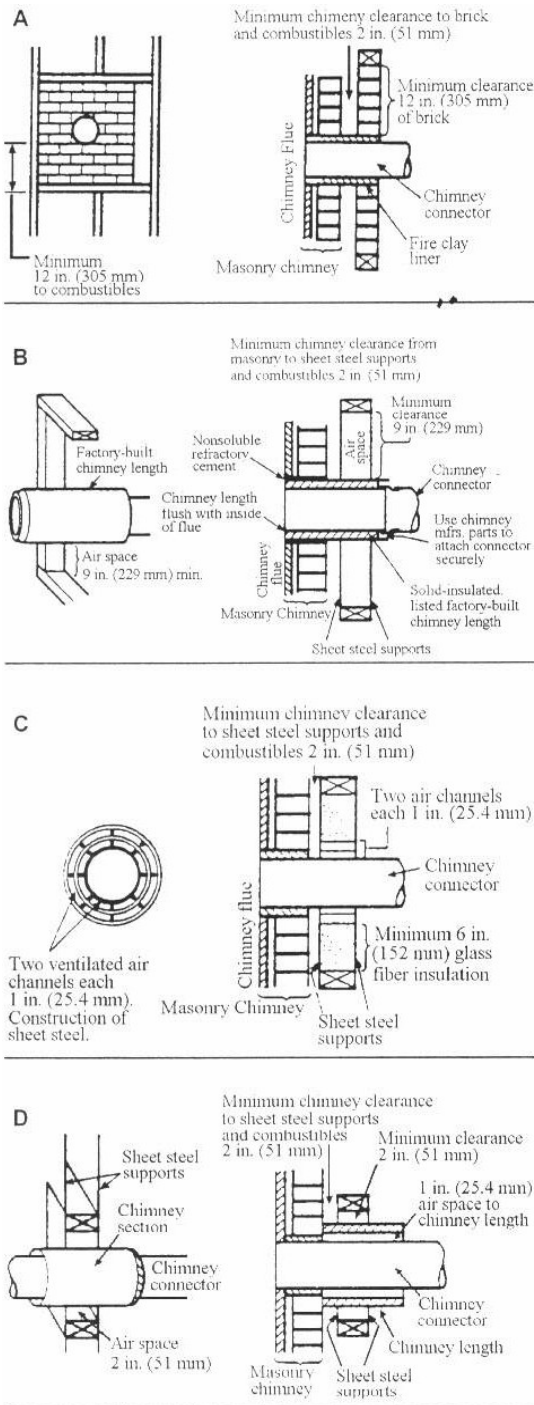

Method A. 12" (305 mm) Clearance to Combustible Wall Member: Using a minimum thickness of 3.5" (90 mm) brick and a 5/8" (16 mm) minimum wall thickness clay liner, construct a wall pass-through. The clay liner must conform to ASTM C315 (Standard Specification for Clay Fire Linings) or its equivalent. Keep a minimum of 12" (305 mm) of brick masonry between the clay liner and wall combustibles. The clay liner shall run from the brick masonry outer surface to the inner surface of the chimney flue liner but not past the inner surface. Firmly grout or cement the clay liner in place to the chimney flue liner.

Method B. 9" (229 mm) Clearance to Combustible Wall Member: Using 6" (152 mm) inside diameter, listed, factory-built Solid-Pak chimney section with insulation of 1" (25.4 mm) or more, build a wall pass-through with a minimum 9" (229 mm) air space between the outer wall of chimney length and wall combustibles. Use sheet metal supports fastened securely to wall surfaces on all sides, to maintain the 9" (229 mm) air space. When fastening support to chimney length, do not penetrate the chimney liner (the inside wall of the Solid-Pak chimney). The inner end of the Solid-Pak chimney section shall be flush with the inside of the masonry chimney flue and sealed with a non-watersoluble, refractory cement. Use this cement to also seal to the brick masonry penetration.

Method C. 6" (152 mm) Clearance to Combustible Wall Member: Starting with a minimum 24 gage (.024 inch [.61 mm]), 6" metal chimney connector, and a minimum 24 gage ventilated wall thimble which has two air channels of 1" (25.4 mm) each, construct a wall pass-through. There shall be a minimum 6" (152 mm) separation area containing fiber glass insulation, from the wall thimble, and cover its opening with a 24-gage minimum sheet metal support. Maintain the 6" (152 mm) space. There should also be a support sized to fit and hold the metal chimney connector. See that the support is fastened securely to wall surfaces on all sides. Make sure fasteners used to secure the metal chimney connector do not penetrate chimney flue liner.

Method D. 2" (51 mm) Clearance to Combustible Wall Member: Start with a Solid-Pak listed factory built chimney section, at least 12" (305 mm) long, with insulation of 1" (25.4 mm) or more, and an inside diameter of 8" (2" [51 mm] larger than the 6" [152 mm] chimney connector). Use this as a pass-through for a minimum 24 gage single wall steel chimney connector. Keep Solid-Pak section concentric with and spaced 1" (25.4 mm) off the chimney connector by wall of steel metal support plates at both ends of chimney section. Cover opening with and support chimney section on both sides with 24 gage minimum sheet metal supports. See that the supports are fastened securely to wall surfaces on all sides. Make sure fasteners used to secure chimney section do not penetrate chimney flue liner.

NOTES:

1. Connectors to a masonry chimney, except for method B, shall extend in one continuous section through the wall pass-through system and the chimney wall, up to but not past the inner liner face.
2. A chimney connector shall not pass through an attic or roof space, closet or similar concealed space, or a floor, or ceiling.
3. Where passage through a wall or partition of combustible construction is desired, the installation shall conform to CAN/CSA-B365.

3. User's Guide

3.1 Hand Protection

Please use protective gloves when opening the doors!!! You can then add wood while the handle is hot

3.2 Technical Data and Dimensions

LASCAR



STROMBOLI

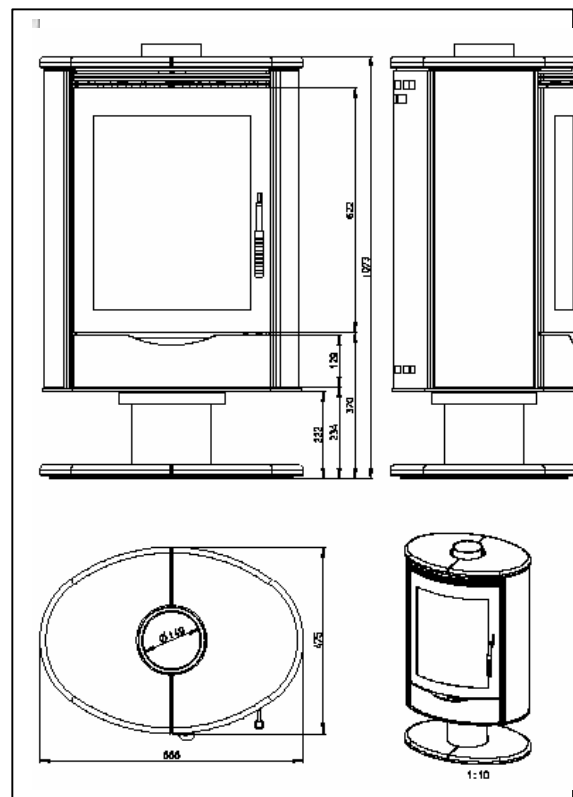
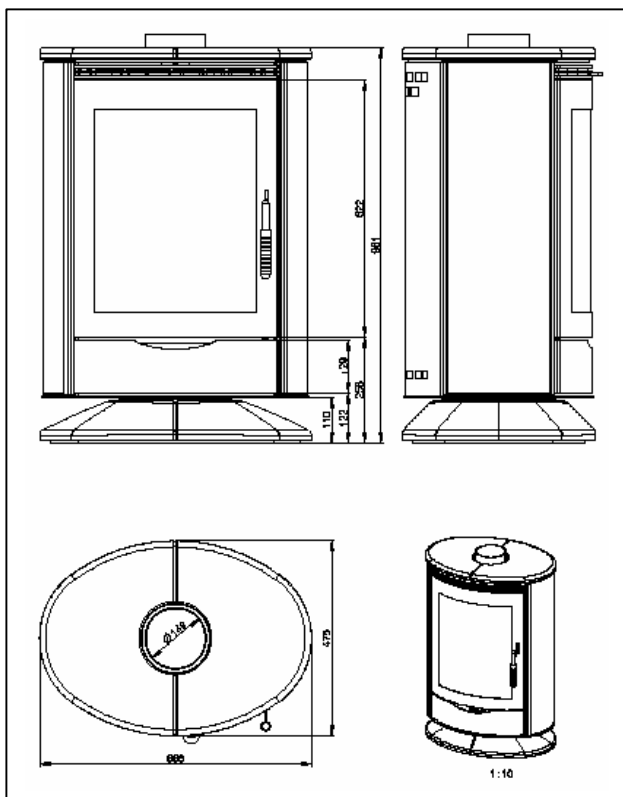

Model	Heat Output	Dimensions h x w x d	Flue Diameter (inner)	Center Height rear design	Weight	Area Heated
	(kW)	(mm)	(mm)	(mm)	(kg)	(m ³)
LASCAR	8	962 x 666 x 475	148	N/A	170 (ceramic) 235 (stone)	150
STROMBOLI	8	1074 x 666 x 475	148	N/A	175 (ceramic) 225 (stone)	150
	Chimney Data				Average Wood Use – Single Load 3-4 pieces of wood, 15-20% moisture	
	Draft	Average	Flue Gas	Flue Gas Heat		
	(Pa)	(cm ²)	(g/s)	(°C)	(kg/h)	
	11	225	7,2	350	2.6	

Note: We reserve the right to make modifications in the interest of technical advances!

Room Heating Capacity

The room heating capacity has a nominal value of 8 kW and is to be calculated as follows, according to DIN 18 893, for rooms that do not have insulation that complies with the Heat Insulation Ordinance:

For favorable heating conditions – calculated according to DIN 4701

At less favorable heating conditions - 145 m³

At unfavorable heating conditions - 98 m³

For interval heating, with interruptions of more than 8 hours, the heating capacity is reduced by 25%.

3.3 Delivery

Damage can occur to the product during transport, even though the packaging appears to be undamaged, upon visual inspection. Therefore, it is important that you inspect the stove itself very carefully and report all damages within one week. In the event of obvious visual damage to the product or its packaging, make a note of this on the shipping papers before accepting the merchandise.

3.4 Unpacking

All cardboard and synthetic materials are recyclable. Please dispose of these at your local recycling center. None of the wooden parts have been surface treated, and they can be used as heating materials for your woodstove. Very carefully open the packaging so that you do not damage anything. Prior to installation, make sure that the base construction can support the weight of the stove! Use only proper lifting aids with adequate support capacities to move your woodstove.

Please do not stand on top of your woodstove; it is not designed to be used as a ladder or scaffolding.



3.5 Acceptable Fuel

Acceptable fuel sources are pieces of wood with a length of 30 cm (12") and a diameter of 10 cm (4"), as well as wood briquettes.

Only air-dried wood should be used. **The burning of waste materials, in particular synthetic materials, is not permitted according to federal laws regulating emissions.** In addition, this causes damage to the fireplace and chimney. Air-dried wood will achieve a maximum water content of 30% after at least 1 year (soft woods) and/or 2 years (hard woods).

Wood is not designed for continuous burning, i.e. heating the fireplace overnight with wood is not possible.

4. Safety (Please read, very important!!!)

- ? Check on a regular basis to make sure that the woodstove has been attached to the chimney in compliance with all regulations.
- ? Carefully read the User's Guide before you use your woodstove for the first time. This will provide you with information about how to safely operate your stove.
- ? **During operation, the woodstove's surface will become very hot. Pay attention, in particular, to children playing in the vicinity of the stove, as they are most likely to be at risk of injury. Keep small children away from the stove.**
- ? Make sure that no combustible material is located in the vicinity of or on top of the woodstove.
- ? Keep the door to the fireplace closed at all times, even if the woodstove is not in operation (with the exception of the initial heating up cycle).
- ? Avoid overloading your woodstove by adding too much fuel at one time.
- ? Never use alcohol, gasoline or other illegal, fire accelerators to start your fire.
- ? No combustible elements should be located within the heat radiation area of your woodstove.
- ? Empty the ash drawer on a regular basis so that it never completely fills up with ashes. Otherwise, the air supply to the woodstove will be blocked.
- ? Always slide the ash drawer back in up to the stop position.
- ? Be sure to provide an adequate supply of fresh air to the woodstove. The stove consumes oxygen.
- ? Do not forget that a kitchen fan that is located in the same or an adjacent room can cause a vacuum situation, which results in a smoke build-up within the room. Make sure that you have a sufficient supply of fresh air.
- ? Never remove hot ashes. Store the ashes in a container that is fire-proof and not combustible.
- ? **Always use the protective glove when operating the woodstove. Do not touch the stove with your bare hand when it is in operation.**
- ? Do not store any combustible liquids in the vicinity of your woodstove!

5. Fresh Air Supply

The woodstove can only be installed in rooms with a sufficient supply of fresh air intake for combustion purposes. This is true of rooms that have at least one exterior door or one window that can be opened. Rooms that are connected to the same fresh air network, i.e. rooms within the same residence or common areas, are also appropriate for installation.

The woodstove requires

approx. 40m³ fresh air per hour for combustion.

With newer, well-insulated houses, and particularly with houses using mechanical air circulation, it is important to supply a sufficient amount of fresh air. Models LASCAR and STROMBOLI have **no** central air intake that directly supplies sufficient air into the combustion process. Therefore, you have to ask your local dealer for a separate air intake.

Important!

Read the User's Guide before you use your woodstove / fireplace for the first time, and do not forget to have your installation inspected by the local authorities before its first fire. Consult your local authorities for any regulations and other information.

The location that is used to support the base of the woodstove must be horizontal and without any uneven spots.

6. Operating Your Woodstove

6.1 Regulating the Heat

A control to regulate the secondary air is located above the door in the middle. Open the faceplate under the fireplace door. Reach into the recess and pull.

- 1) Secondary Draft Control

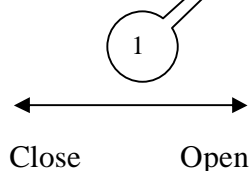

The **secondary draft control** lever regulates the amount of air that is needed to reburn exhaust gases that are produced in the fireplace during the wood burning process. A portion of this secondary air circulates from the top to the door and helps to keep the glass window clean.

The fire intensity can be regulated with the secondary draft control lever.

Creosote - Formation and Need for Removal - When wood is burned slowly, it produces tar and other organic vapors, which combine with expelled moisture to form creosote. The creosote vapors condense in the relatively cool chimney flue of a slow-burning fire. As a result, creosote residue accumulates on the flue lining. When ignited this creosote makes an extremely hot fire. Burning wood, the chimney connector and chimney should be inspected at least once every two months during the heating season to determine if a creosote buildup has occurred.

6.2 Door

Caution: Use protective glove!!!

When adding wood, pull the door handle up. The door opens from the side. After you have finished, remember to securely lock the door again by pressing it back in.

Warning: Be careful in using the door. Never operate a stove with a broken Glass!!!

A torsion spring is used to automatically close this door. This spring should never be disabled (refer to DIN 18891, Type 1). The door must be locked manually.



6.3 Ash Drawer

The ashes will fall down into the ash drawer after you pull on the grate lever several times. Do not forget that ashes will remain hot for several days in the ash drawer. Only use sheet metal ash containers to empty ashes out! LASCAR and STROMBOLI have no tool drawer.

A fire should never be started in the woodstove if the ash drawer is not in its proper position!

Disposal of Ashes - Ashes should be placed in a metal container with a tight fitting lid. The closed container of ashes should be placed on a noncombustible floor or on the ground, well away from all combustible materials, pending final disposal. If the ashes are disposed of by burial in soil or otherwise locally dispersed, they should be retained in the closed container until all cinders have thoroughly cooled.

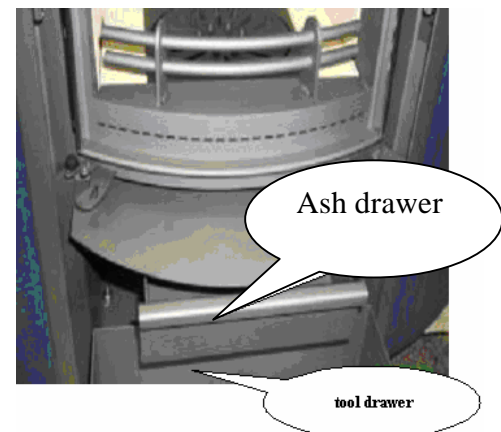

7. Heating Operation

7.1 First Use

Your new woodstove should not be used until after you have obtained approval from the proper authorities regarding its proper installation and conditions of use.

The woodstove is designed to burn only wood, i.e. pieces of wood or wood briquettes.

The wood must be dry (moisture ? 20%) and untreated. The burning of any other materials, such as chipboard, painted, laminated, impregnated, or synthetic coated wood, garbage, etc. is prohibited and causes irresponsible damage to the environment, as well as damage to your complete fireplace system.

- ? Have you removed all accessories from the ash pan and the fireplace?
- ? Check to make sure that no objects are located on top of the woodstove.
- ? Are the conventional / standard openings free and accessible?
- ? Keep the door to the fireplace partially open during the first lighting of your woodstove, as long as the fire has not gone out. The same applies to the ash pan. A special, heat-treated paint was used on your stove, and its hardening process is not completely "burned in" until after the first lighting. By keeping the door and ash pan partially open, this will prevent the gasket seals from adhering to the paint.

Unpleasant smells that occur during the first lighting are normal. Provide good air ventilation to your room to remove these odors. (!!! Heat until peak temperature is reached!!!)

7.2 Starting a Fire

It is important to engage the wood in a trouble-free combustion process as quickly and safely as possible. In order to accomplish this, the wood should be layered in the woodstove as follows:

Never use alcohol, gasoline or similar substances, including glossy paper, to light the fire. It does not burn properly, and its printed colors produce highly toxic elements in the fumes.

- ? Place newspaper or a solid fire starter, along with some kindling wood, in the fireplace. Stack the wood in a criss-crossed pile. Open the primary and secondary draft controls as far as possible. As long as the fire has not started burning completely, you can leave the ash pan slightly opened. This will warm up the glass window and prevent soot coating.
- ? As soon as the fire gets going, close the ash pan.
- ? For the next supply of fuel, spread out the burning embers in even layers and add approximately three (3) larger pieces of wood. After the wood starts to burn, you can close the primary draft control. The secondary draft control remains open.
- ? After a period of time, as soon as the fire is burning well, it might seem as if the heat output is less. Regulate the burning process first by the amount of wood in the stove. At the same time, the secondary draft can be reduced.
- ? The air supply for burning and for heat output is dependent upon the fireplace draft, moisture and size of wood.

7.3 Environmentally Safe Heating

Too much wood can result in an overheating situation. In this case, there is too much stress on the woodstove, and poor flue gas values result. If there is not enough wood, then the stove will not reach the required operating temperature. As a result, the wood does not burn up cleanly, and soot is built up on the glass and the fireclay walls. Therefore, fill your woodstove about halfway with wood pieces and replenish on a regular basis. Your woodstove is not a garbage burning incinerator. Use only wood or wood briquettes for fuel.

7.4 Adding Wood

Do not add wood until the flames have stopped blazing.

First open the draft controls completely, then slowly open the doors and add wood. Be sure to open the doors slowly to avoid a possible flame-up.

Close the doors after you have added the wood. If the fire was almost burned out before you added more wood, keep the draft controls in a fully open position for approx. 5-10 minutes. Then move the controls to the center position for normal operation. After heating up and the addition of wood, soot can accumulate on the fireclay parts and glass window, but this will burn itself off again with the increase in fireplace temperature. If wet wood is used, a large amount of soot will accumulate on your woodstove. Therefore, do not burn wood with a moisture content of more than 20%.

7.5 Maximum Fuel Supply

The woodstove is designed for a maximum fuel supply, per load, of 2.5 kg of split wood or 1.5 kg of wood briquettes. If these maximum levels are exceeded, this may result in damages to your stove.

7.6 Putting the Fire Out

As soon as the fire has burned down and the wood is no longer glowing, close the primary and secondary draft air supplies. **If the air supply controls are closed while the fire is still burning or the wood is still glowing, the resultant exhaust gas buildup in the woodstove can cause an explosion which breaks the glass window.** The woodstove will continue to give off heat for some time. Otherwise, the stove will cool faster, due to the supply of fresh (cold) air, i.e. the thermal energy escapes out the chimney.

7.7 Heating during Transition Periods

During transition periods (Spring / Fall), outside temperatures of over 16°C can cause a smoke buildup in the woodstove. If sufficient draft cannot be created with a startup fire at this temperature (= rapid generation of high heat by quick burning of newspaper), so that the fumes are not completely removed, then you should abandon your plans for a fire. Use newspaper as fuel for a startup fire. Add less wood during transition periods or wait longer before adding more wood.

The fireplace should be filled with less fuel (wood) and operated at a higher setting of the primary draft control lever so that the existing fuel burns faster (in flames), which will stabilize the chimney draft. In addition, the wait time between adding wood for reheating should be extended. To avoid resistance in the firebed, ashes should be carefully scraped off on a regular basis.

8. Cleaning and Maintenance

Very important: All cleaning and maintenance work must only be performed on a completely cooled down fireplace!!!

8.1 Door Gasket Seal

The door is equipped with a special ceramic seal. This prevents an unwanted vacuum exhaust of combustion air. The woodstove can then be regulated with the primary and secondary draft control levers.

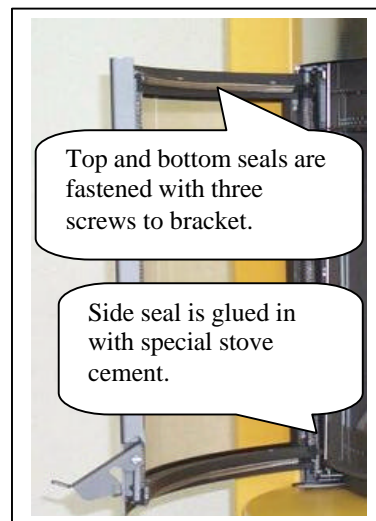

8.2 Cleaning the Woodstove

Fireplace stoves are designed so that the secondary air draft also serves as a “rinsing air” for the glass window. With proper installation and correct positioning of the chimney, the glass will remain generally clean on its own. Despite this fact, a buildup of a fine layer of soot dust is often unavoidable, and this is magnified by poor fuel (wet wood) and/or constant draft with limited efficiency.

Important: Only clean the glass after the woodstove has completely cooled!!!

Warning: Do not use abrasive cleaners!!!

Only clean the glass after the woodstove has completely cooled. Use some moist paper that has been dipped in the cool ashes to remove the soot on the glass window. As a final step in the cleaning process, use some fresh paper with clean water to rinse the window. Even if the chimney is not cleaned every year, the joints between the oven and the chimney should be cleaned every year. In general, you should keep the fireplace and flue clean at all times.

Small cracks in the baffle bricks, due to heat stress, are unavoidable and will not have an adverse effect on its function or durability under normal operating conditions. Consult your dealer if you notice more extensive damage.

Check the door gasket seal on a regular basis for damage and replace, if necessary.

Keep the fireplace and flue clean. If you are a frequent user of your woodstove, you should also have the chimney cleaned on a regular basis.

If a fire should occur in the chimney or a real risk of fire exists, immediately close the draft intake lever and the door. If necessary, call the fire department to extinguish the fire. Always call the local authorities after a chimney fire so that the chimney can be inspected. If a gray haze should appear on the outer surface after an overheating situation, this can be removed and/or touched up with specialty spray paint for woodstoves.

9. Troubleshooting

9.1 Poor Draft Conditions

- ? Is the chimney too short?
- ? Is the chimney or flue leaking?
- ? Is the flue protruding out from the chimney?
- ? Is the door from another fireplace that is connected to the same chimney, open?

9.2 Woodstove does not give off enough heat

- ? Is the room too large?
- ? Are there too many ashes on the grate?
- ? Is the ash pan full?
- ? Is the flue obstructed?
- ? Are the primary and secondary draft air control levers closed?
- ? Is the connection between the stove and the chimney sealed or leaking?

9.3 Woodstove gives off too much heat

- ? Are the primary and secondary draft air control levels open too far?
- ? Is the stove door closed properly? Is the ash pan completely closed?
- ? Is the chimney too tall?
- ? Have you added too much wood?

10. Important

Damages that occur as a result of improper operation are not covered under warranty.

11. Fire Safety (Please read, very important!!!)

Teach your children about fire safety, and, in particular, keep them as far away as possible from the woodstove while it is in operation. The heating process causes the top surface of the woodstove, as well as its operating elements, including the window and flue, to become extremely hot. Do not touch any of these parts without appropriate protective gear or tools, e.g. heat protection gloves. Never put laundry or other objects on the stove to dry. Objects that are not heat-resistant should never be placed on top of the woodstove or in the vicinity of the stove. Drying racks for drying clothing or similar items must be set up at a sufficient distance away from the heating device. Never heat and/or store flammable or explosive materials, such as empty spray cans and similar objects, in or around the immediate fireplace area as this can cause an explosion. Do not wear loose or easily combustible clothing when starting the fire or adding wood. As long as your woodstove is in operation, do not work with easily combustible or explosive materials in the same or adjacent rooms.

12. Warranty

It is important for you to read the attached Warranty Statement before operating your woodstove. It contains information about the duties and responsibilities that must be met before a warranty claim can be made.



13. Replacement Parts List

13.1 Replacement Tiles

13.2 Replacement Glas and Door Handle

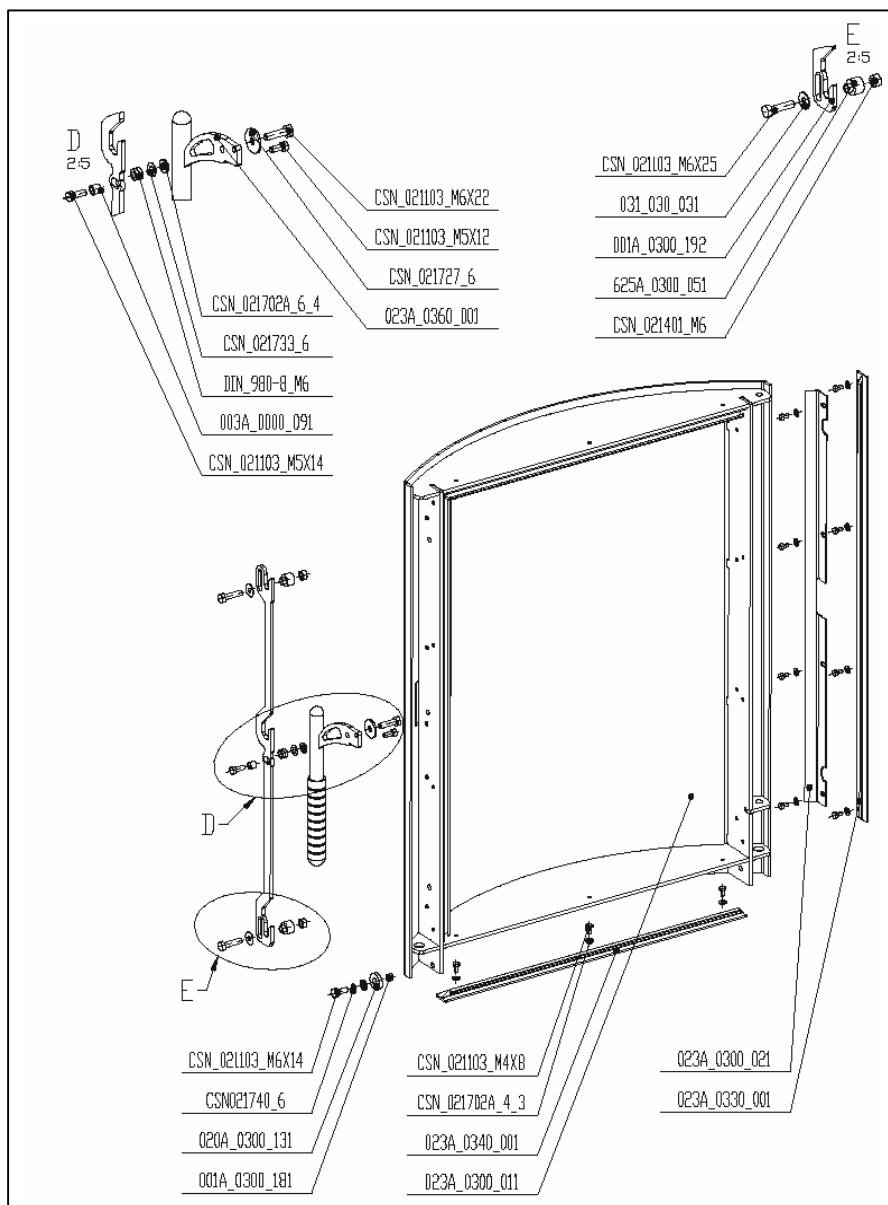

Glass Dimensions:	
Height:	550.0mm
Width:	420.0mm
Thickness:	4.0mm
Radius:	420.0mm

IMPORTANT: Replace glass only with glass from the manufacturer or distributor of this appliance

13.3 Replacement Baffel Bricks

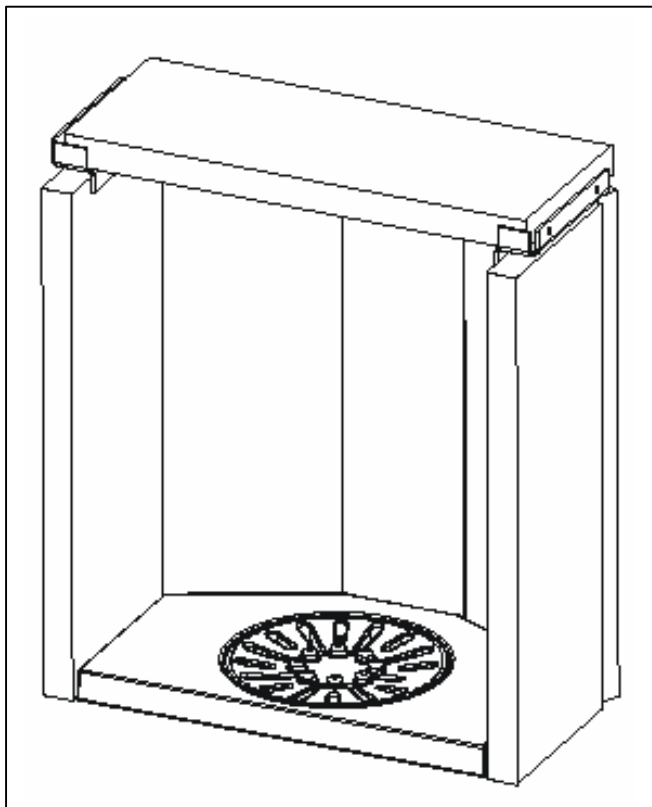

IMPORTANT: Replace Baffel Bricks only with Baffel Bricks from the manufacturer or distributor of this appliance

We sincerely hope that your Wolf Bavaria woodstove provides you with many cozy hours of warmth and enjoyment.

Manufactured by:



**Frohnhof 9
91580 Petersaurach
Germany
T: ++49 9802 951473
F: ++ 49 9802 9589909
www.wolf-bavaria.com**

Imported by:



**PO Box 120
Pound Ridge, NY
USA
T: 914 764 5679
F: 614 764 0465
www.wittus.com**

