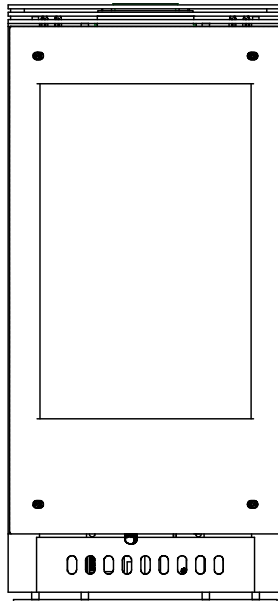


### PALOMA FREESTANDING FIREPLACE

Model:

PALOMA-BL  
PALOMA-BZ  
PALOMA-GR  
PALOMA-GY



### CAUTION

#### DO NOT DISCARD THIS MANUAL



- Important operating and maintenance instructions included.
- Read, understand and follow these instructions for safe installation and operation.
- Leave this manual with party responsible for use and operation.



**WARNING:** If the information in these instructions is not followed exactly, a fire or explosion may result causing property damage, personal injury, or death.

- Do not store or use gasoline or other flammable vapors and liquids in the vicinity of this or any other appliance.
- **What to do if you smell gas**
  - Do not try to light any appliance. Do not touch any electrical switch. Do not use any phone in your building.
  - Immediately call your gas supplier from a neighbor's phone. Follow the gas supplier's instructions.
  - If you cannot reach your gas supplier, call the fire department.
- Installation and service must be performed by a qualified installer, service agency, or the gas supplier.

### WARNING



**HOT! DO NOT TOUCH. SEVERE BURNS MAY RESULT. CLOTHING IGNITION MAY RESULT.**



Glass and other surfaces are hot during operation and cool down.

- Keep children away.
- CAREFULLY SUPERVISE children in same room as appliance.
- Alert children and adults to hazards of high temperatures.
- Do NOT operate with protective barriers open or removed.
- Keep clothing, furniture, draperies and other combustibles away.

In the Commonwealth of Massachusetts:

- installation must be performed by a licensed plumber or gas fitter.
- a CO detector shall be installed in the room where the appliance is installed.

This appliance may be installed as an OEM installation in manufactured home (USA only) or mobile home and must be installed in accordance with the manufacturer's instructions and the manufactured home construction and safety standard, *Title 24 CFR, Part 3280 or Standard for Installation in Mobile Homes, CAN/CSA Z240MH.*

This appliance is only for use with the type(s) of gas indicated on the rating plate.



Installation and service of this appliance should be performed by qualified personnel. Hearth & Home Technologies suggests NFI certified or factory-trained professionals, or technicians supervised by an NFI certified professional.





# - TABLE OF CONTENTS -

Section 1: Listing and Code Approvals		Section 8: Appliance Setup	
A. Appliance Certifications .....	4	A. Remove Shipping Materials .....	31
B. Glass Specifications.....	4	B. Unbolting Appliance from the Pallet....	31
C. Specifications.....	4	C. Accessories.....	31
D. High Altitude Installations.....	4	D. Top to Rear Conversion.....	32
Section 2: Getting Started		E. Shutter Adjustment .....	33
A. Design & Installation		F. Installing the Vent Restrictor .....	33
Considerations.....	5	G. Installing the Baffle.....	34
B. Tools and Supplies Needed .....	5	H. Lagging Down Appliance-Required ....	34
C. Inspect Appliance & Components.....	5	I. Positioning the Logs.....	34
Section 3: Appliance Location & Clearances		J. Mineral Wool .....	35
A. Selecting Appliance Location .....	6	K. Optional Blower.....	35
B. Clearances to Combustibles.....	6	L. Remote Controls .....	39
C. Optional Stone Surround Installed.....	7	M. Front Door Glass Assembly	
Section 4: Termination Locations		Installation.....	41
A. Vent Termination Minimum		N. Inner Glass Door Assembly	
Clearances .....	8	Replacement.....	41
Section 5: Vent Information		Section 9: Operating Instructions	
A. Venting Components .....	10	A. Before Lighting Appliance .....	42
B. Use of Elbows.....	10	B. Controls.....	42
C. Measuring Standards.....	10	C. Lighting Appliance.....	43
D. How to Use the Vent Graph.....	11	D. After Appliance is Lit .....	44
E. Venting Guidelines.....	11	E. Frequently Asked Questions.....	44
F. Horizontal Termination.....	12	Section 10: Troubleshooting.....	45
G. Vertical Termination .....	15	Section 11: Maintaining & Servicing Appliance .....	47
H. Slim Line Wall Thimble .....	23	A. Maintenance Tasks .....	48
Section 6: Gas Information		Section 12: Reference Materials	
A. Fuel Conversions.....	25	A. Appliance Dimension Diagram .....	50
B. Gas Pressures.....	27	B. Appliance Dimension With Stone	
C. Gas Connection.....	28	Surround Diagram .....	51
Section 7: Electrical Information		C. Vent Components Diagram .....	52
A. Recommendation for Wire .....	29	D. Vent Components List .....	53
B. Connecting to the Appliance .....	29	E. Service Parts List.....	54
C. IntelliFire® Pilot Ignition System		F. Accessories .....	58
Wiring.....	29	G. Warranty Policy.....	59
D. Loss of Power & Battery		H. Contact Information .....	60
Backup Usage.....	30		

# 1

## Listing and Code Approvals

### A. Appliance Certification

<b>MODEL</b>	Paloma
<b>LABORATORY</b>	OMNI-Test Laboratories, Inc. 061-S-63-5
<b>TYPE</b>	Vented Gas Fireplace Heater
<b>STANDARD</b>	ANSI Z21.88b-2003 · CSA 2.33b-2003 · UL307b · CAN/CBA 2.17-M91

The product is listed to ANSI standards for "Vented Gas Appliance Heaters" and applicable sections of "Gas Burning Heating Appliances for Manufactured Homes and Recreational Vehicles" and "Gas Fired Appliances for use at High Altitudes".

Manufactured Home or Mobile Home installation may occur only after the home is site located and must conform with the Manufactured Home Construction and Safety Standard, Title 24 CFR, Part 3280, or, when such a standard is not applicable, the Standard for Manufactured Home Installations, ANSI/NCSCS A225.1, or Standard for Gas Equipped Recreational Vehicles and Mobile Housing, CSA Z240.4.

When installed, the appliance must be electrically grounded in accordance with local codes or, in the absence of local codes, with the National Electrical Code, ANSI/NFPA 70, or the Canadian Electrical Code, CSA C22.1.

**NOT INTENDED FOR USE AS A PRIMARY HEAT SOURCE.** This appliance is tested and approved as either supplemental room heat or as a decorative appliance. It should not be factored as primary heat in residential heating calculations.

### B. Glass Specifications

This stove is equipped with 5mm ceramic glass behind the curved glass. Replace glass only with 5mm ceramic glass. Please contact your dealer for replacement glass.

**NOTE:** This installation must conform with local codes. In the absence of local codes you must comply with the **National Fuel Gas Code, ANSI Z223.1-latest edition** in the U.S.A. and the **CAN/CGA B149 Installation Codes** in Canada.

### C. Specifications

<b>Model</b> <i>(US or Canada)</i>	Maximum Input BTU	Minimum Input BTU	Orifice Size (DMS)	Steady State Efficiency* %	AFUE %	P4* %
<b>Paloma (NG)</b>	30,000	22,500	36	82.5	71	69
<b>Paloma (LP)</b>	28,000	22,650	52	81	72.5	71

\*Maximum Vent Blower On

\*\*Canada Only

### D. High Altitude Installations

Omni-Test Laboratories, Inc. listed gas appliances are tested and approved without requiring changes for elevations from 0 to 2000 feet in the U.S.A. and 0 to 4500 feet in Canada.

When installing this appliance at an elevation above 2000 feet, it may be necessary to decrease the input rating by changing the existing burner orifice to a smaller size. Input rate should be reduced by 4% for each 1000 feet above a 2000 foot elevation in the U.S.A., If the heating value of the gas has been reduced, these rules do not apply. To identify the proper orifice size, check with the local gas utility.

If installing this appliance at an elevation above 4500 feet (in Canada), check with local authorities.



### WARNING

Do NOT use this appliance if any part has been under water. Immediately call a qualified service technician to inspect the appliance and to replace any part of the control system and any gas control which has been under water.

# 2

## Getting Started

### A. Design & Installation Considerations

Heat & Glo direct vent gas appliances are designed to operate with all combustion air siphoned from outside of the building and all exhaust gases expelled to the outside. No additional air source is required.

#### CAUTION

- Check building codes prior to installation.
- Installation **MUST** comply with local, regional, state and national codes and regulations.
  - Consult local building, fire officials or authorities having jurisdiction about restrictions, installation inspection, and permits.

When planning an installation, it is necessary to determine the following information before installing.

- Where the appliance is to be installed.
- The vent system configuration to be used.
- Gas supply piping.
- Electrical wiring.
- Whether optional accessories - devices such as a blower, thermostat or remote control - are desired.

#### WARNING



- Keep appliance dry.
- Mold or rust may cause odors.
  - Water may damage controls.



### B. Tools and Supplies Needed

Before beginning the installation be sure that the following tools and building supplies are available. **Note: Not all tools will apply to every installation.**

- |   |                       |
|---|-----------------------|
| Pliers  | Gloves                |
| Hammer  | Framing Square        |
| Phillips Screwdriver  | Electric Drill / Bits |
| Flat Blade Screwdriver  | Safety Glasses        |
| Plumb Line  | Voltmeter             |
| Level   | Wrenches              |
| Manometer   | Allen Wrench Set      |
| Tape Measure  | Ratchets / Sockets    |
| 1/2 - 3/4 in. length, #6 or #8 Self-Drilling Screws           |                       |
| Non-corrosive Leak Check Solution or Combustible Gas Detector |                       |

### C. Inspect Appliance & Components

#### WARNING



Inspect appliance and components for damage. Damaged parts may impair safe operation.



- Do NOT install damaged components.
- Do NOT install incomplete components.
- Do NOT install substitute components.

Report damaged parts to dealer.

- Carefully remove the appliance and components from the packaging.
- Remove door and set aside on protective surface. See page 38.
- Remove log set and component pack from firebox.
- Report to your dealer any parts damaged in shipment, particularly the condition of the glass.
- **Read all of the instructions before starting the installation. Follow these instructions carefully during the installation to ensure safety and benefit.**

#### WARNING



Hearth & Home Technologies disclaims any responsibility for, and the **warranty will be voided** by, the following actions:

- Installation and use of any damaged appliance or vent system component.
- Modification of the appliance or vent system.
- Installation other than as instructed by Hearth & Home Technologies.
- Improper positioning of the gas logs or the glass door.
- Installation and/or use of any component part not approved by Hearth & Home Technologies.

**Any such action may cause a fire hazard.**

# 3 Appliance Location and Clearances

**NOTE:**

- Illustrations reflect typical installations and are FOR DESIGN PURPOSES ONLY.
- Illustrations/diagrams are not drawn to scale.
- Actual installation may vary due to individual design preference.

**WARNING**



Fire Risk  
Provide adequate clearance:

- Around air openings
- To combustibles
- For service access

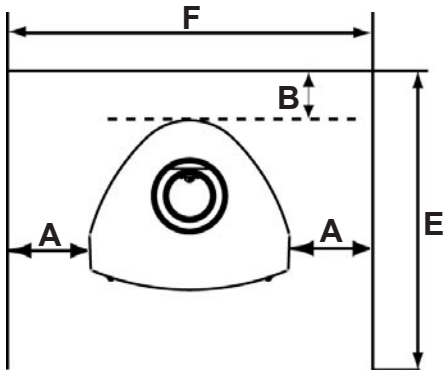
Locate appliance away from traffic areas.

## A. Selecting Appliance Location

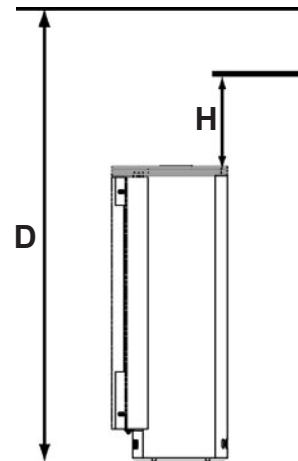
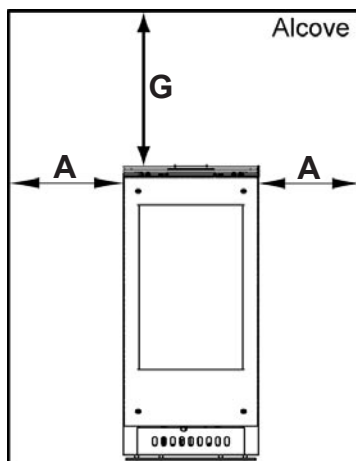
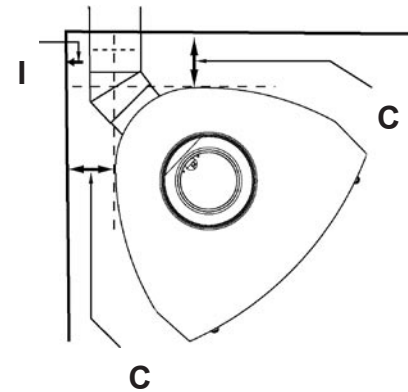
When selecting a location for your appliance it is important to consider the required clearances to wall (see Figure 3.1).

**NOTE:** For actual appliance dimensions refer to Section 12.

## B. Clearances to Combustibles



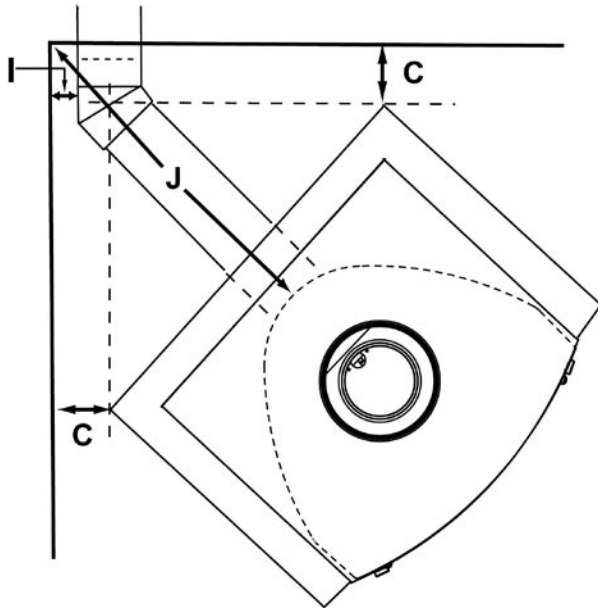
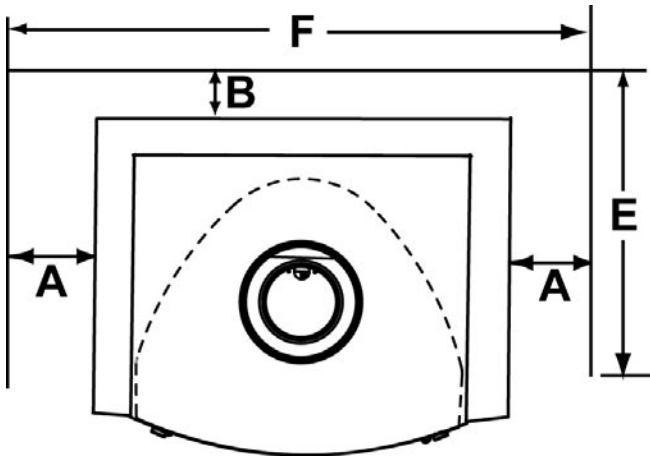
“A” measurement is from appliance top, not side.




Model		A	B	C	D	E	F	G	H	I
Paloma	Inches	6	3	5	54	36	30-3/4	13-1/4	13-1/4	1
	Millimeters	152	76	127	1372	914	781	337	337	25

Figure 3.1

### C. Optional Stone Surround Installed



	<b>⚠ WARNING</b>
	<p>Fire Risk.</p> <ul style="list-style-type: none"> <li>Locate and install appliance to all clearance specifications in manual.</li> </ul>

	<b>⚠ WARNING</b>
	<p>Fire Risk. Odor Risk. Tipping Risk</p> <ul style="list-style-type: none"> <li>Install appliance on a stable, level platform/ floor strong enough to support appliance without tipping.</li> <li><u>USE</u> wood flooring, ceramic tile, brick hearth or high pressure laminate flooring applied directly over the sub-flooring material.</li> </ul>

Model		A	B	C	E	I	J
Paloma Surround	Inches	3-1/4	4	4-3/4	36	1	20*
	Millimeters	83	102	121	914	25	508

\*Distance is measured from flue collar to corner

**NOTE:** Flooring beneath appliance may reach 90 degrees plus room ambient temperature. Check with flooring manufacturer for maximum temperature allowed on flooring surfaces.

# 4 Termination Locations

## A. Vent Termination Minimum Clearances

**WARNING**

Fire Risk.  
Explosion Risk.  
Maintain vent clearance to combustibles as specified.

- Do not pack air space with insulation or other materials.

Failure to keep insulation or other materials away from vent pipe may cause fire.

Measure vertical clearances from this surface.

Measure horizontal clearances from this surface.

(See **Figure 4.4** for specific clearances.)

**Figure 4.1 Termination Clearances**

	Gas Termination	Wood & Fuel Oil Termination
A	6 in. (152mm)	20 in. (508mm)

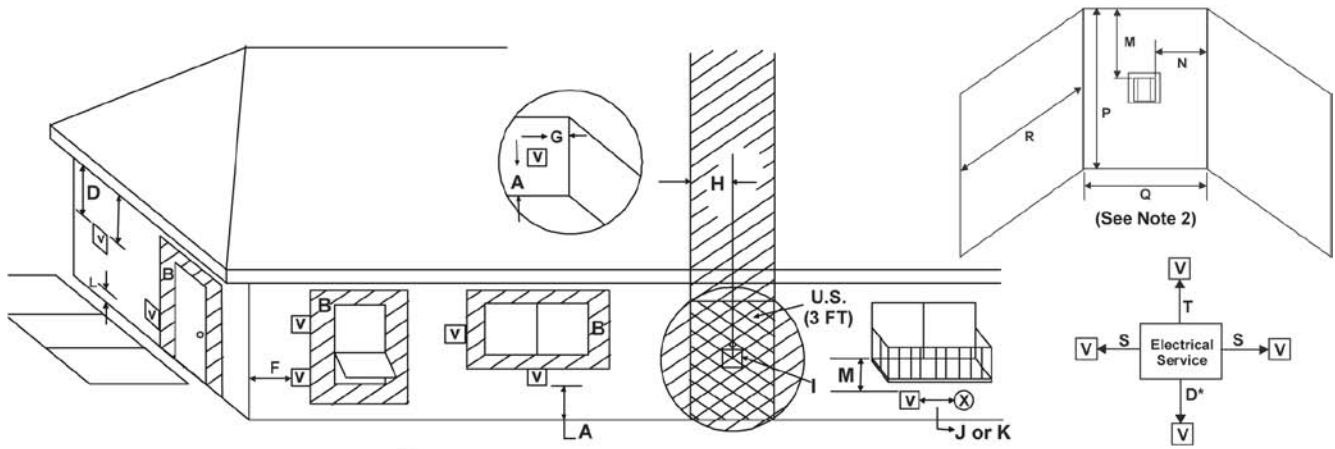
**Figure 4.2 Multiple Vertical Termination**

Roof Pitch	H (Min.) Ft.
Flat to 6/12	1.0*
6/12 to 7/12	1.25*
Over 7/12 to 8/12	1.5*
Over 8/12 to 9/12	2.0*
Over 9/12 to 10/12	2.5*
Over 10/12 to 11/12	3.25
Over 11/12 to 12/12	4.0
Over 12/12 to 14/12	5.0
Over 14/12 to 16/12	6.0
Over 16/12 to 18/12	7.0
Over 18/12 to 20/12	7.5
Over 20/12 to 21/12	8.0

\* 3 foot minimum in snow regions

**Figure 4.3 Minimum Height from Roof to Lowest Discharge Opening**

**Figure 4.3** specifies minimum vent heights for various pitched roofs.



**V** = VENT TERMINAL      **X** = AIR SUPPLY INLET      [Hatched] = AREA WHERE TERMINAL IS NOT PERMITTED

<p><b>A</b> = 12 inches ..... clearances above grade, veranda, porch, deck or balcony (See Note 1)</p> <p><b>B</b> = 12 inches ..... clearances to window or door that may be opened, or to permanently closed window. (Glass)</p> <p><b>D*</b> = 12 inches ..... vertical clearance to unventilated soffit or to ventilated soffit located above the terminal *30 inches ..... for vinyl clad soffits and below electrical service</p> <p><b>F</b> = 9 inches ..... clearance to outside corner</p> <p><b>G</b> = 6 inches ..... clearance to inside corner</p> <p><b>H</b> = 3 ft. (Canada) ..... not to be installed above a gas meter/regulator assembly within 3 feet (90cm) horizontally from the center-line of the regulator</p> <p><b>I</b> = 3 ft. (U.S.A.) 6 ft. (Canada) ..... clearance to gas service regulator vent outlet</p> <p><b>J</b> = 9 inches (U.S.A.) 12 inches (Canada) ..... clearance to non-mechanical air supply inlet to building or the combustion air inlet to any other appliance</p>	<p><b>K</b> = 3 ft. (U.S.A.) 6 ft. (Canada) ..... clearance to a mechanical (powered) air supply inlet</p> <p><b>L**</b> = 7 ft. .... clearance above paved sidewalk or a paved driveway located on <b>public</b> property (See Note 1)</p> <p><b>M***</b> = 18 inches ..... clearance under veranda, porch, deck, balcony or overhang 42 inches ..... vinyl</p> <p><b>S</b> = 6 inches ..... clearance from sides of electrical service (See Note 3)</p> <p><b>T</b> = 12 inches ..... clearance above electrical service (See Note 3)</p>
--	---

Alcove Applications		
<b>N</b> = 6 inches	non-vinyl sidewalls	
	12 inches ..... vinyl sidewalls	
<b>P</b> = 8 ft.		
	<b>Q<sub>MIN</sub></b>	<b>R<sub>MAX</sub></b>
1 cap	3 feet	2 x Q <sub>ACTUAL</sub>
2 caps	6 feet	1 x Q <sub>ACTUAL</sub>
3 caps	9 feet	2/3 x Q <sub>ACTUAL</sub>
4 caps	12 feet	1/2 x Q <sub>ACTUAL</sub>
Q <sub>MIN</sub> = # termination caps x 3      R <sub>MAX</sub> = (2 / # termination caps) x Q <sub>ACTUAL</sub>		

\*\* a vent shall not terminate directly above a sidewalk or paved driveway which is located between two single family dwellings and

\*\*\* only permitted if veranda, porch, deck or balcony is fully open on a minimum of 2 sides beneath the floor, or meets Note 2.

**NOTE 1:** On private property where termination is less than 7 feet above a sidewalk, driveway, deck, porch, veranda or balcony, use of a listed cap is suggested. (See vents components pages.)

**NOTE 2:** Termination in an alcove space (spaces only open on one side and with an overhang) are permitted with the dimensions specified for vinyl or non-vinyl siding and soffits. **1.** There must be at least 3 feet minimum between termination caps. **2.** All mechanical air intakes within 10 feet of a termination cap must be a minimum of 3 feet below the termination cap. **3.** All gravity air intakes within 3 feet of a termination cap must be a minimum of 1 foot below the termination cap.

**NOTE 3:** Location of the vent termination must not interfere with access to the electrical service.

**NOTE:** Local codes or regulations may require different clearances.

**NOTE:** Termination caps may be hot. Consider their proximity to doors or other traffic areas.

**WARNING: In the U.S.:** Vent system termination is **NOT** permitted in screened porches. You must follow side wall, overhang and ground clearances as slated in the instructions.

**In Canada:** Vent system termination is **NOT** permitted in screened porches. Vent system termination is permitted in porch areas with two or more sides open. You must follow side wall, overhang and ground clearances as slated in the instructions.

Heat & Glo assumes no responsibility for the improper performance of the appliance when the venting system does not meet these requirements.

**CAUTION: IF EXTERIOR WALLS ARE FINISHED WITH VINYL SIDING, IT IS SUGGESTED THAT A VINYL PROTECTOR KIT BE INSTALLED.**

Figure 4.4

# 5

## Vent Information

### A. Venting Components

In order to comply with applicable codes and product warranties, use only following venting components:




- Hearth & Home Technologies (HHT)
- Security Chimney's Secure Vent Chimney System
- Selkirk
- AmeriVent
- Simpson Dura-Vent (SDV)

**DO NOT USE FIELD-FABRICATED VENTING COMPONENTS.** Refer to the venting manufacturer's instructions.

This product is approved to be vented either horizontally, through the side wall or vertically through the roof. You may vent through a Class A or masonry chimney if an approved adapter is used (for USA installations only).

This appliance is a direct vent heater. All combustion air must come directly from the outside of the building. The vent pipe for this appliance consists of an inner and an outer pipe. The inner pipe carries the appliance exhaust out of the system, and the outer pipe brings fresh combustion air into the appliance.

- A wall thimble/heat shield is required when the venting passes through a combustible wall.
- A support box or firestop is required when the venting-passes through a ceiling.
- Roof flashing and a storm collar are required when venting passes through the roof.
- Follow instructions provided with the vent for installation of these items.

 <b>WARNING</b>	
	Fire Hazard. Explosion Risk. Asphyxiation Risk. Do NOT connect this gas appliance to a chimney flue serving a separate solid-fuel or gas burning appliance.
	<ul style="list-style-type: none"><li>• Vent this appliance directly outside.</li><li>• Use separate vent system for this appliance.</li></ul>
	May impair safe operation of this appliance or other appliances connected to the flue.

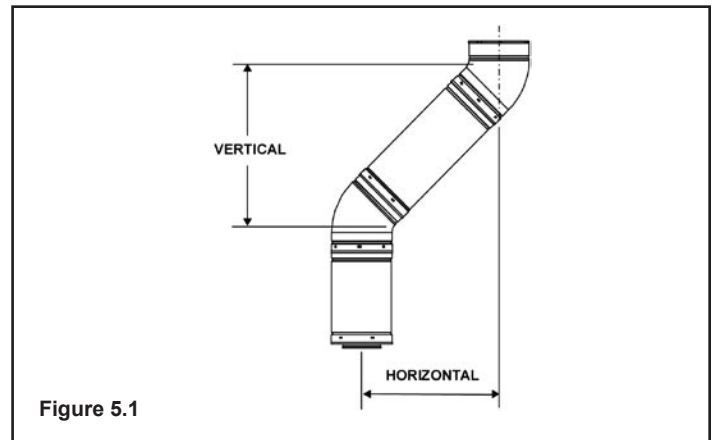
### B. Use of Elbows

#### CAUTION

- ALL vent configuration specifications MUST be followed.
- This product is tested and listed to these specifications.
  - Appliance performance will suffer if specifications are not followed.

Diagonal runs have both vertical and horizontal vent aspects when calculating the effects. Use the rise for the vertical aspect and the run for the horizontal aspect. (See **Figure 5.1**)

Two 45° elbows may be used in place of one 90° elbow. On 45° runs, one foot of diagonal is equal to 8-1/2 in. (216mm) horizontal run and 8-1/2 in. (216mm) vertical run. A length of straight pipe is allowed between two elbows. (See **Figure 5.1**)



### C. Measuring Standards

Vertical and horizontal measurements were made using the following standards.

1. Pipe measurements are from center line to center line.
2. Horizontal terminations are measured to the outside of the mounting surface (flange of exterior firestop) (See **Figure 4.1** on page 8)
3. Vertical terminations are measured to the top of the last pipe before termination cap.

## D. How to Use the Vent Graph

1. Measure the distance from the top of appliance to the center of the 90° elbow. On the graph below, draw a horizontal line from that measurement on the vertical axis across until it intersects with the slanted line.
2. From the point of this intersection, draw a vertical line to the bottom of the graph.
3. The point at which this line meets the bottom line of the graph is the maximum length of the horizontal run.

**Example 1:** If the vertical dimension from the top of the stove to the center of the 90° elbow is 7 ft. (2.13m), the horizontal run to the outer wall flange must not exceed 13 ft. (3.96m).

**Example 2:** If the vertical dimension from the top of the stove is 21 ft. (6.4m), the horizontal run to the outer wall flange must not exceed 9 ft. (2.74m).

4. Each 90° elbow is equivalent to 3 ft. (914mm) of vent pipe and each 45° elbow is equivalent to 1 ft. (305mm) of vent pipe, and must be subtracted from vent pipe run. A single vertical to horizontal 90° elbow is already calculated into the allowable 15 ft. (457cm) run. Each additional 90° elbow reduces the maximum horizontal distance by 3 ft. (914mm).

**Example:** The use of three elbows would reduce the allowable horizontal run to 9 ft. (3 - 1 = 2 elbows x 3 ft. = 6 ft.; 15 ft. max. - 6 ft. = 9 ft. max.)

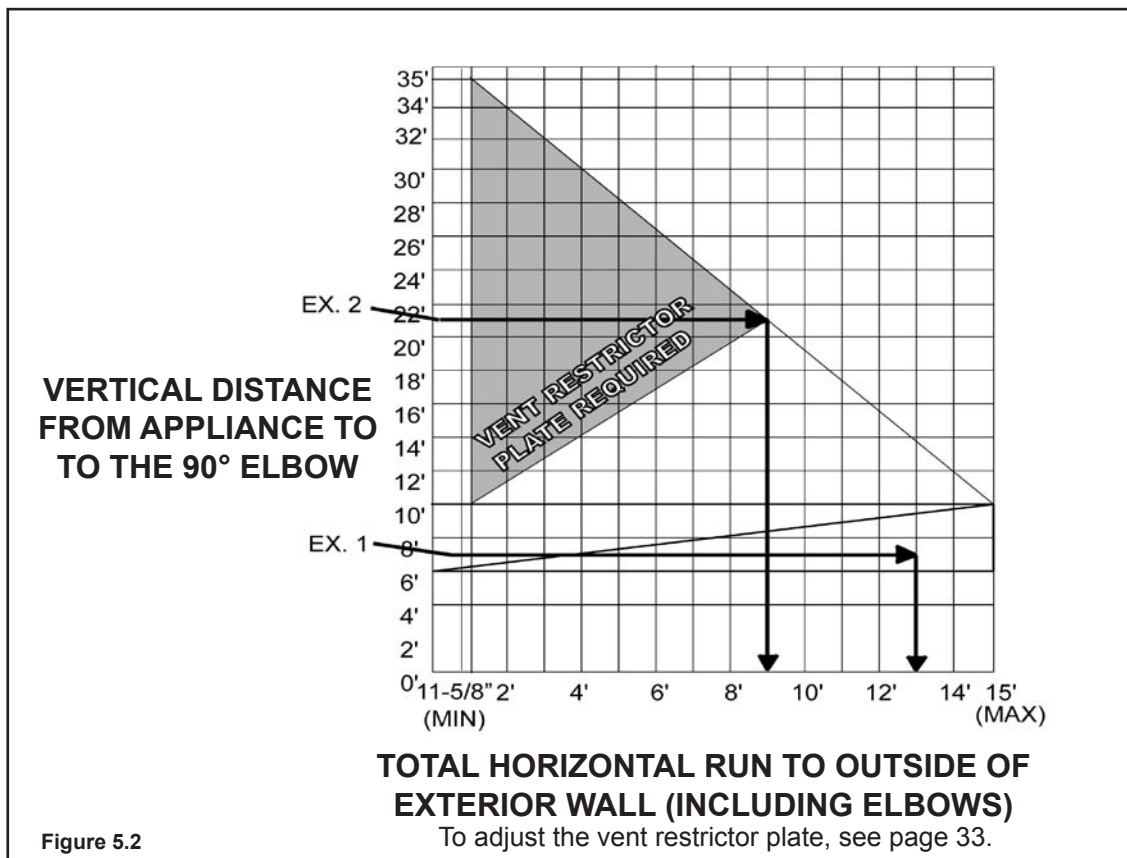
## E. Venting Guidelines

### Notes:

- The maximum horizontal vent run is 15 ft. (457cm) when the vertical vent rise is 10 ft. (305cm).
- The minimum horizontal vent run is 11-5/8 in. (295mm).
- Horizontal sections require a 1/4 in. (6mm) rise for every 12 in. (305mm) of horizontal travel.
- Horizontal sections require noncombustible support every 3 ft. (914mm), e.g. plumbing tape.
- Wall thickness: Minimum 4 in. (102mm). Maximum 20 in. (508mm).
- Vent Diameter: Exterior 6-5/8 in. (168mm); Inner 4 in. (102mm)

### EXCEPTION FOR REAR VENT KIT (Snorkel Kit SLK-SNKD), HORIZONTAL INSTALLATION:

- The maximum horizontal vent run is 3 ft. (914mm).
- The maximum horizontal vent run with a 45° elbow is 2 ft. (610mm).
- No external minimum rise is required. The minimum horizontal vent run is 11-5/8 in. (295mm).
- For any vertical rise when rear venting, a minimum of 2 ft. (610mm) vertical must be used prior to any horizontal run.



## F. Horizontal Termination

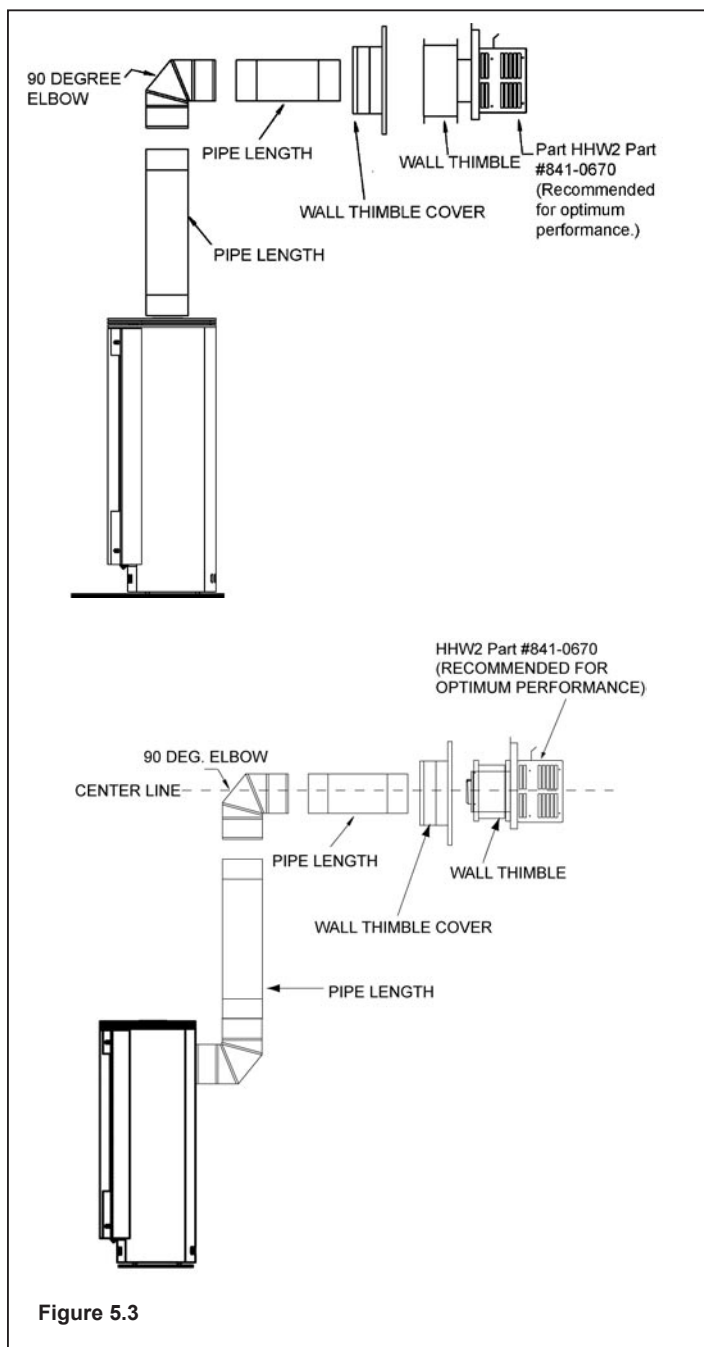


Figure 5.3

**Note:** Direct vent pipe is designed to slide straight onto the male ends of adjacent pipes and fittings by orienting the four pipe indentations on the female ends so they match and slide into the four entry slots on the male ends, see **Fig. 5.4**. Push the pipe sections completely together, then twist-lock one section clockwise approximately one-quarter turn, until the two sections are fully locked. The female locking lugs will not be visible from the outside, on the pipe or fittings. They may be located by examining the inside of the female ends.

**NOTE:**

Horizontal runs of vent must be supported every 3 ft. (91cm). Wall straps are available for this purpose.

Horizontal sections require a 1/4 in. (6mm) rise for every 12 in. (305mm) of horizontal travel.

Exterior Vent Diameter = 6-5/8 in. (177mm); Inner Vent Diameter = 4 in. (102mm).

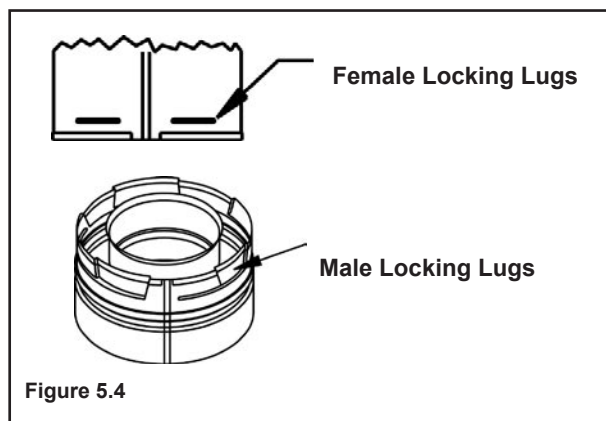


Figure 5.4

**Step 3.**

For installations using a wall thimble (check pipe manufacturer's instructions), mark the wall for a 10 in. x 10 in. (254mm x 254mm) square hole. The center of the square hole should line up with the centerline of the horizontal pipe, as shown in **Fig. 5.5**, on the next page. Cut and frame the hole in the exterior wall where the vent will be terminated. If the wall being penetrated is constructed of noncombustible material, i.e. masonry block or concrete, a 7 in. (178mm) diameter hole is acceptable.

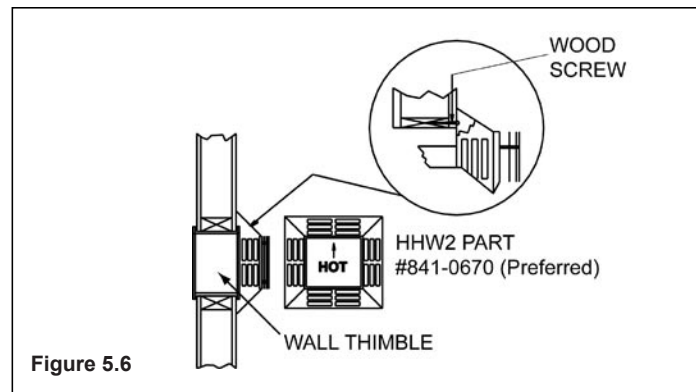
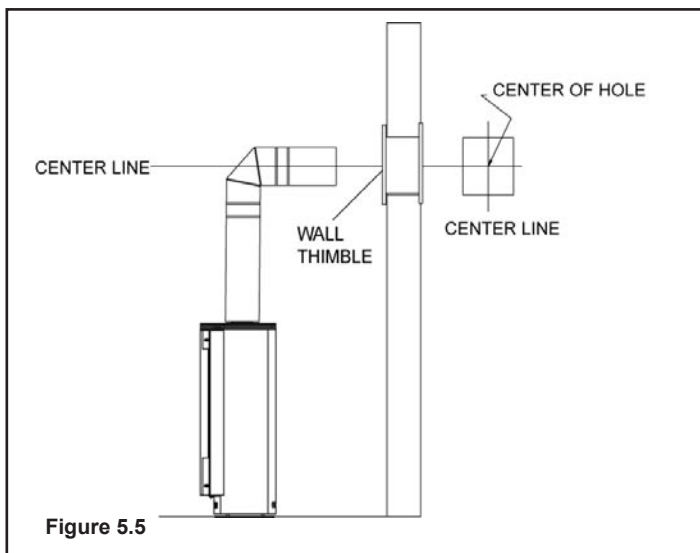
**Step 1.**

Determine the desired location of the appliance. Check to ensure that wall studs or roof rafters are not in the way when the venting system is being planned. If this is the case, you may want to adjust the location of the appliance.

**Step 2.**

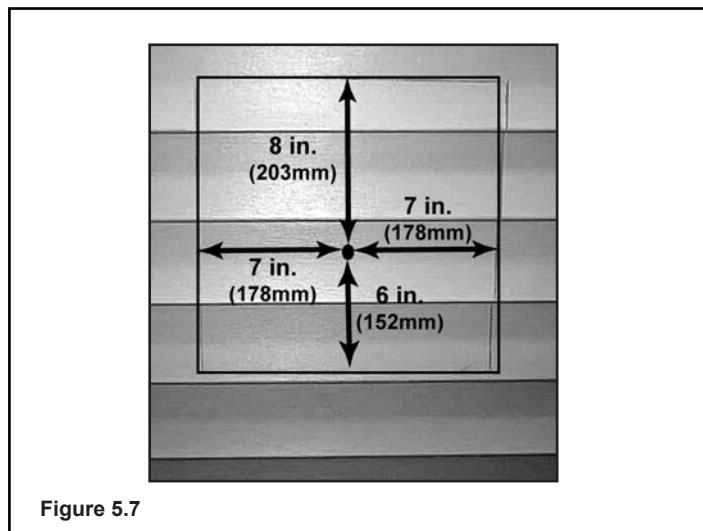
Direct vent pipe is designed with a locking connection. To connect the venting system to the appliance flue outlet, a twist-lock adapter is built into the appliance at the factory. Remember to include thickness of wall in minimum clearances when figuring the measurements for your installation needs.

## F. Horizontal Termination-(Cont'd)



### NOTES:

- (1) The four wood screws provided should be replaced with appropriate fasteners for stucco, brick, concrete, or other types of sidings.
- (2) Termination cap HHW2 (Part #841-0670) is highly recommended on a building with vinyl siding, as the vinyl siding standoff is built in. The pilot hole will be 2 in. (51mm) closer to the bottom of the square than the top. Using a framing square, draw a 14 in. x 14 in. (356mm x 356mm) square around the pilot hole. See **Figure 5.7**.



### NOTE:

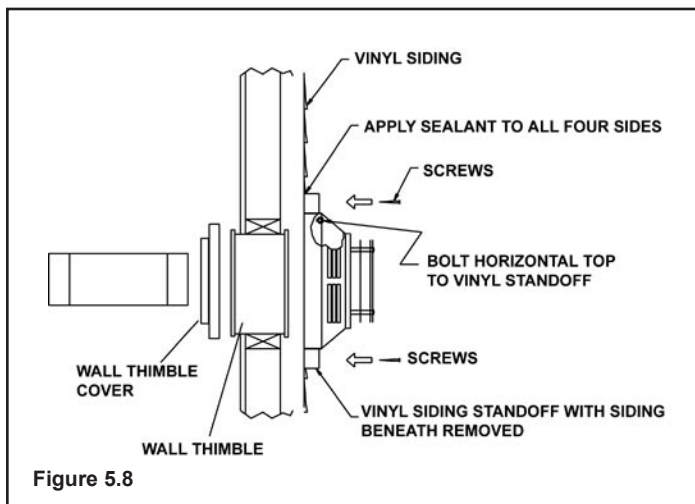
- (1) Installation requires a minimum of 6 in. (152mm) horizontal run of vent with a 1/4 in. (6mm) rise run towards the termination. Each 1 ft. (305mm) of horizontal venting must include a 1/4 in. (6mm) rise. Never allow the vent to run downward. This could cause high temperatures and may present the possibility of a fire.
- (2) The location of the horizontal vent termination on an exterior wall must meet all local and national building codes, and must not be easily blocked or obstructed, see **Figure 4.4** on page 9.
- (3) For installations requiring a vertical rise on the exterior of the building, HHT RHVK snorkel kit (Part #844-8921), 14 in. (356mm) or 36 in. (914mm) tall snorkel terminations are available. Follow the same installation procedures as used for standard horizontal terminations. If the snorkel termination must be installed below grade (i.e. basement application), proper drainage must be provided to prevent water from entering the snorkel termination. Do not backfill around snorkel termination.



### Step 4.


Position the horizontal vent termination in the center of the 10 in. x 10 in. (254mm x 254mm) square hole and run a bead of non-hardening mastic around its outside edges, so as to make a seal between it and the wall, attach termination cap to the exterior wall with the four wood screws provided. The arrow on the vent cap should be pointing up (**Figure 5.6**)

**NOTE:** If you are installing termination cap HHW2, the pipe will be off center on the flashing). Ensure that proper clearances to combustible materials are maintained. If you are using an approved termination cap on a building with vinyl siding, a vinyl siding standoff, should be installed between the vent cap and the exterior wall (**Figure 5.8**, on the next page). Attach the vinyl siding standoff to the horizontal vent termination. The vinyl siding standoff prevents excessive heat from possibly melting the vinyl siding material. Vent terminal shall not be recessed into a wall or siding. Remove siding from behind area of standoff.

## F. Horizontal Termination-(Cont'd)



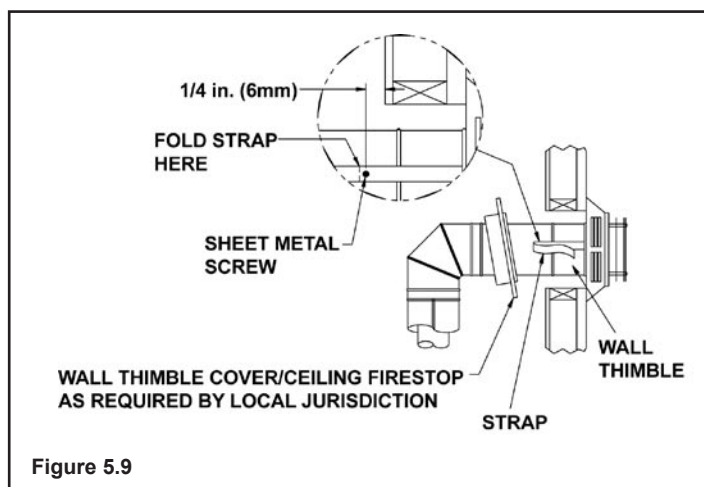
<b>⚠ WARNING</b>	
	<p>Fire Risk. Explosion Risk. Maintain vent clearance to combustibles as specified.</p>
	<ul style="list-style-type: none"> <li>Do not pack air space with insulation or other materials.</li> </ul> <p>Failure to keep insulation or other materials away from vent pipe may cause fire.</p>

<b>⚠ WARNING</b>	
	<p>Burn Risk.</p> <ul style="list-style-type: none"> <li>Local codes may require installation of a cap shield to prevent anything or anyone from touching the hot cap.</li> </ul>

### Step 5.

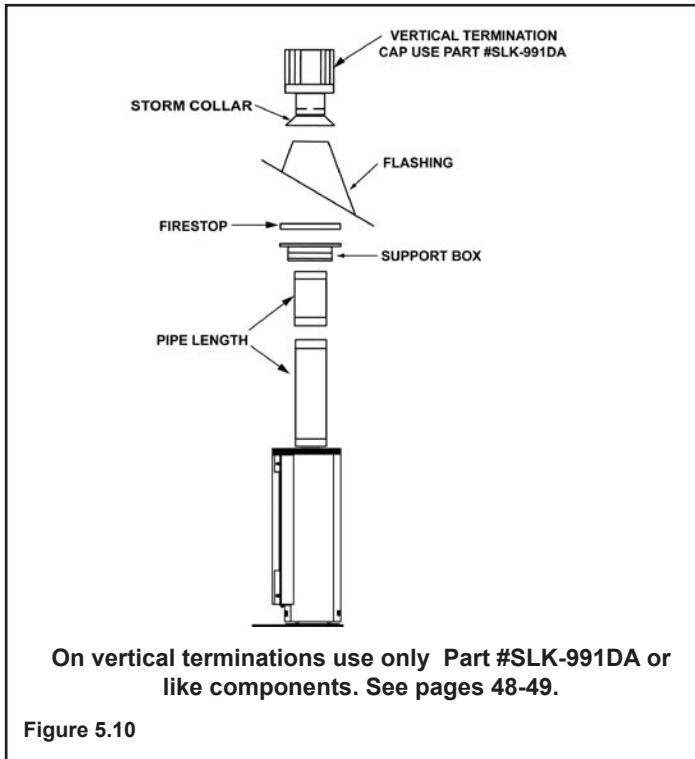
Slide the stove and vent assembly towards the wall, carefully inserting the vent pipe into the vent cap assembly. It is important that the vent pipe extend into the vent cap a sufficient distance so as to result in a minimum pipe overlap of 1-1/4 in. (32mm). Secure the connection between the vent pipe and the vent cap by attaching the two sheet metal strips extending from the vent cap assembly into the outer wall of the vent pipe. Use the two sheet metal screws provided to connect the strips to the pipe section (**Figure 5.9**).

**Note:** The attachment from the vent pipe to the vent cap must be sealed with silicone. Venting terminals shall not be recessed into a wall or siding.



## G. Vertical Termination

### 1. Direct Vent Pipe

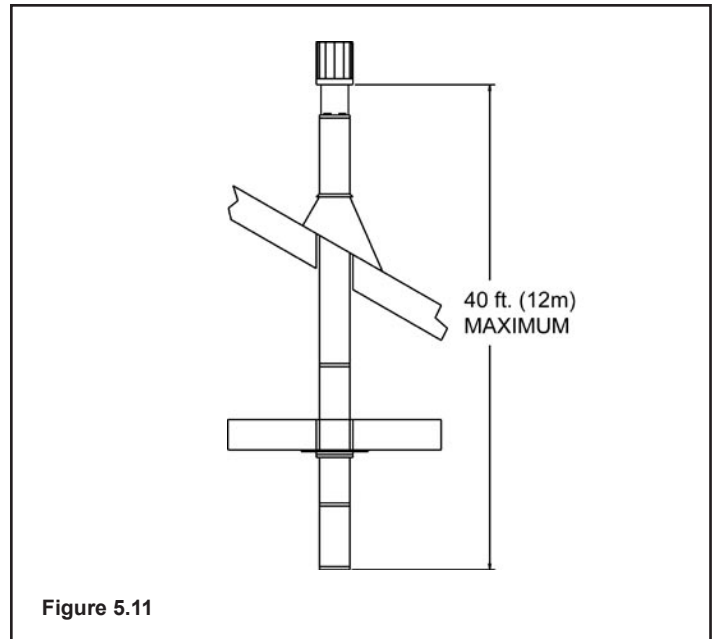


#### Step 1.

Check the installation instructions for required 1 in. (25mm) clearances (air space) to combustibles when passing through ceilings, walls, roofs, enclosures, attic rafters, or other nearby combustible surfaces. See page 17, **Figure 5.16**. Do not pack air space with insulation. Check the instructions below for maximum vertical rise of the venting system, and any maximum horizontal offset limitations. All offsets must fall within the set parameters of the vent graph (**Figure 5.2**) located on page 11.

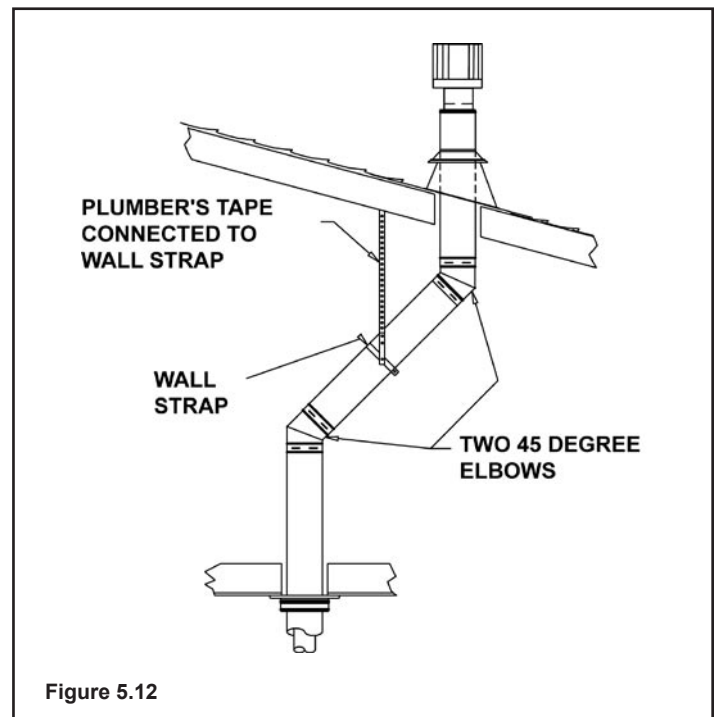
**NOTE:** Maximum vertical rise allowable is 40 ft. (10.7m), **Figure 5.11**.

**NOTE:** Maximum number of 45° elbows permitted for a vertical installation is eight, provided their installation does not decrease maximum allowable horizontal run (as specified by vent graph, on page 11).



#### Step 2.

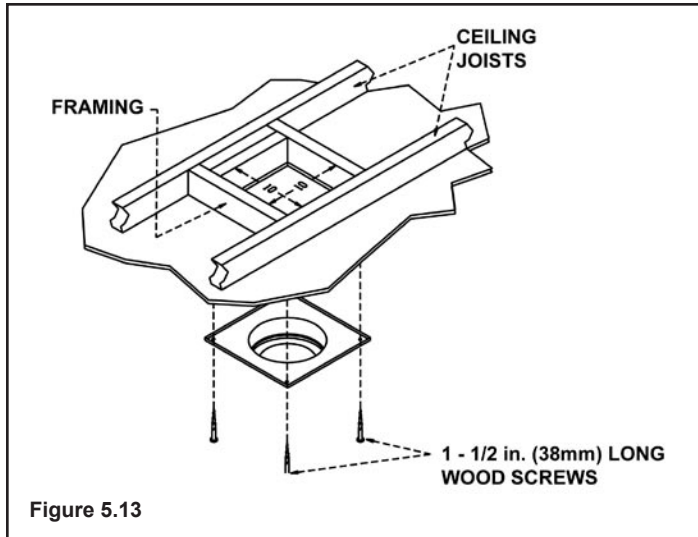
Set the gas appliance in its desired location. Drop a plumb bob down from the ceiling to the position of the appliance flue exit, and mark the location where the vent will penetrate the ceiling. Drill a small hole at this point. Next, drop a plumb bob from the roof to the hole previously drilled in the ceiling, and mark the spot where the vent will penetrate the roof. Determine if ceiling joists, roof rafters, or other framing will obstruct the venting system. You may wish to relocate the appliance, or to offset, as shown in **Figure 5.12** to avoid cutting loadbearing members.



## 1. Direct Vent Pipe-(Cont'd)

### Step 3.

To install the round support box/wall thimble in a flat ceiling, cut a 10 in. (254mm) square hole in the ceiling, centered on the hole drilled in Step 2. Frame the hole as shown in **Figure 5.13**.



### Step 4.

Assemble the desired lengths of pipe and elbows necessary to reach from the appliance up through the round support box. Ensure that all pipe and elbow connections are in their fully twist-locked position. Be sure to seal the outer pipe with appropriate sealant (high temperature silicone).

### Step 5.

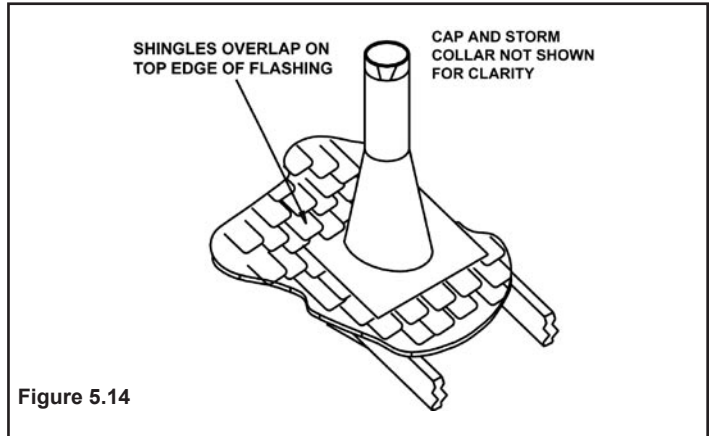
Cut a hole in the roof centered on the small drill hole placed in the ceiling in Step 2. The hole should be of sufficient size to meet the minimum requirements for clearance to combustibles, as specified. Continue to assemble lengths of pipe and elbows necessary to reach from the ceiling support box up through the roof line. Galvanized pipe and elbows may be utilized in the attic, as well as above the roofline. The galvanized finish is desirable above the roofline, due to its higher corrosion resistance.

### NOTE:

- (1) If an offset is necessary in the attic to avoid obstructions, it is important to support the vent pipe every 3 ft. (914mm) to avoid excessive stress on the elbows, and possible separation. Wall straps are available for this purpose, **Figure 5.12**, page 15.
- (2) Whenever possible, use 45° elbows, instead of 90° elbows. The 45° elbow offers less restriction to the flow of flue gases and intake air.

### Step 6.

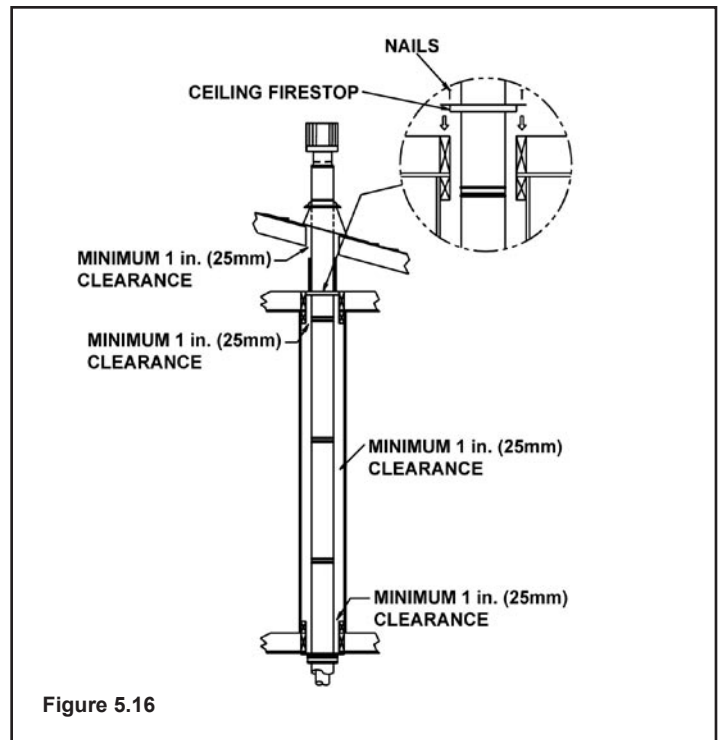
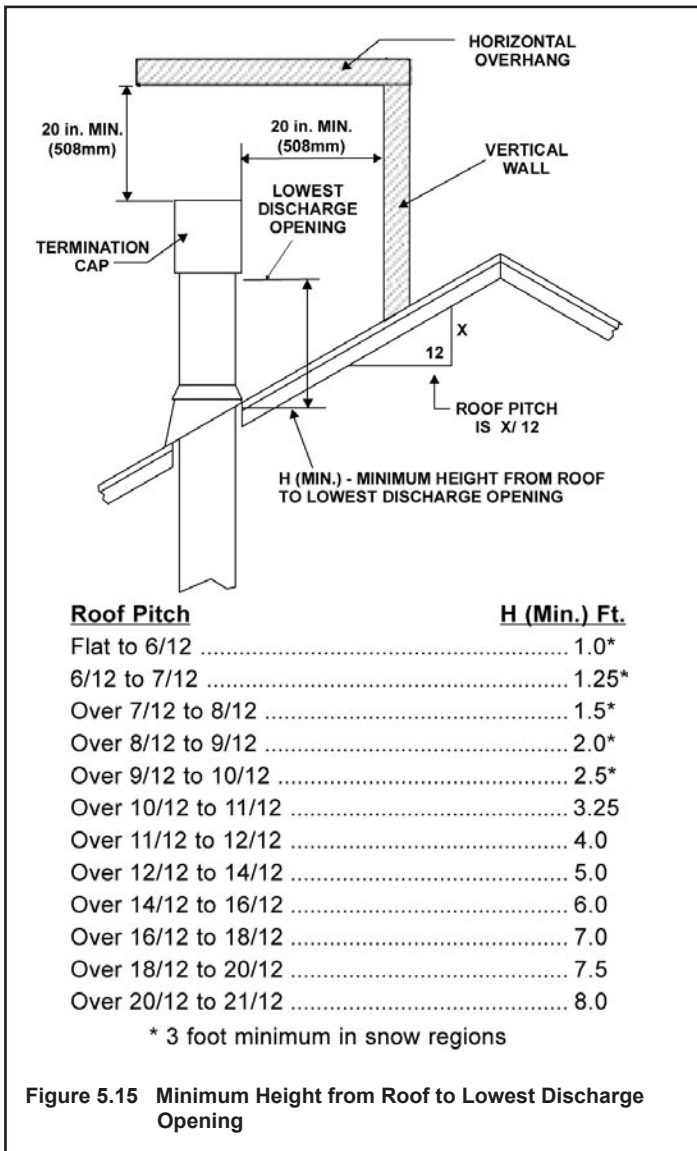
Slip the flashing over the pipe section(s) protruding through the roof. Secure the base of the flashing to the roof with roofing nails. Ensure the roofing material overlaps the top edge of the flashing as shown in **Figure 5.14**. Verify that the chimney is the required height above the roof. See Roof Pitch Table on page 17 of this manual.



### Step 7.

Continue to assemble pipe sections until the height of the vent cap meets the minimum code requirements as outlined in the current CAN/CGA-B149 Installation Codes (in Canada), the National Fuel Gas Code NFPA 54/ANSI Z223.1 (in USA), or local codes. Note that for steep roof pitches, the vent height must be increased. See Roof Pitch Table (**Figure 5.15**, on next page). In high wind conditions, nearby trees adjoining rooflines, steep pitched roofs, and other similar factors can result in poor draft, or down drafting. In these cases increasing the vent height may solve this problem.

# 1. Direct Vent Pipe-(Cont'd)



**WARNING**

Fire Risk.  
Explosion Risk.

- Any occupied areas above the first floor, including closets and storage spaces, which the vertical vent passed through must be enclosed. The enclosure may be framed and sheetrocked with standard construction materials; however, refer to these installation instructions for the minimum allowable clearance between the outside of the vent pipe and the combustible surfaces of the enclosure. Do not fill any of the required air space with insulation.

## Step 8.

Twist-lock the vent cap and seal.

### Note:

- (1) For multi-story vertical installations, a ceiling firestop is required at the second floor, and any subsequent floors (Figure 5.16). The opening should be framed to 10 in. x 10 in. (254mm x 254mm) inside dimensions, in the same manner as shown in Figure 5.13, page 16.
- (2) Any occupied areas above the first floor, including closets and storage spaces, which the vertical vent passed through must be enclosed. The enclosure may be framed and sheetrocked with standard construction materials; however, refer to these installation instructions for the minimum allowable clearance between the outside of the vent pipe and the combustible surfaces of the enclosure. Do not fill any of the required air space with insulation.

## 2. Cathedral Ceiling

### Step 1.

Follow installation Steps 1 and 2 under vertical installation section, page 15.

### Step 2.

Using the plumb-bob, mark the centerline of the venting system on the ceiling, and drill a small hole through the ceiling and roof at this point. From the roof, locate the drill hole and mark the outline of the cathedral ceiling support box.

### Step 3.

Remove shingles or other roof covering as necessary to cut the rectangular hole for the support box. Cut the hole 1/8 in. (3mm) larger than the support box outline.

### Step 4.

Lower the support box through the hole in the roof until the bottom of the box protrudes at least 2 in. (51mm) below the ceiling (**Figure 5.17**). Align the support box both vertically and horizontally with a level. Temporarily tack the support box in place through the inside walls and into the roof sheathing.

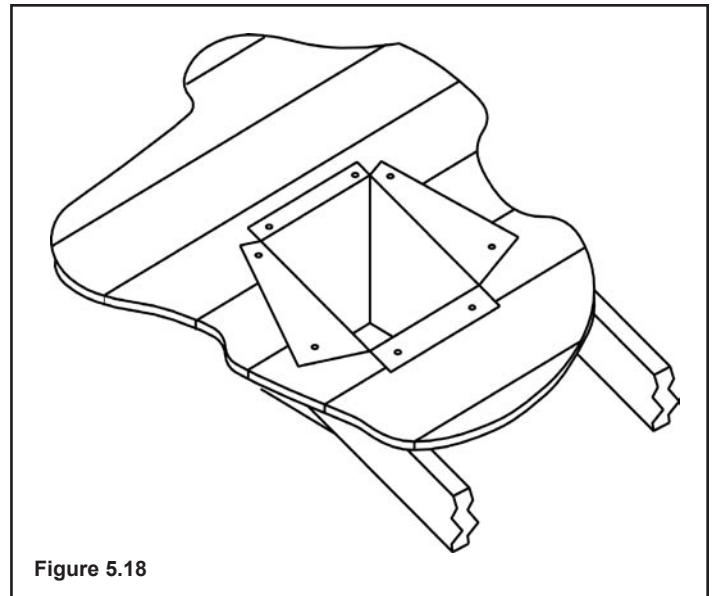


Figure 5.18

### Step 6.

Complete the cathedral ceiling installation by following the same procedures outlined in steps 4 through 8 for vertical installations, pages 16-17.

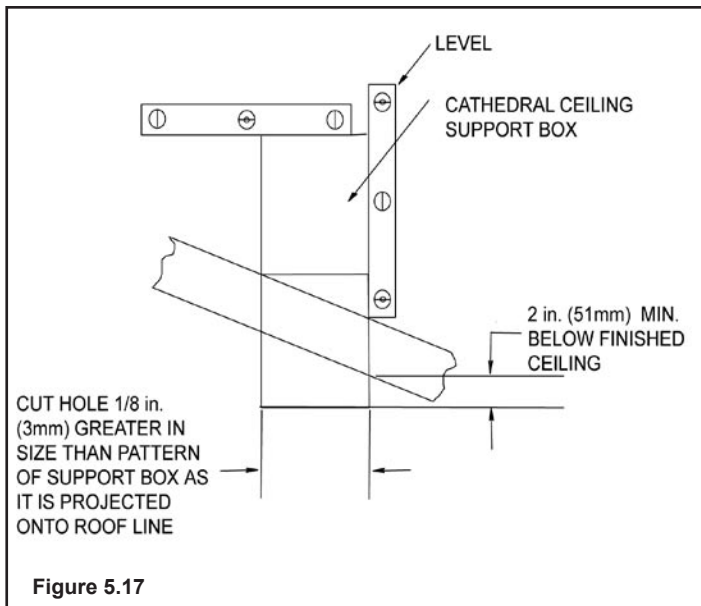


Figure 5.17

### Step 5.

Using tin snips, cut the support box from the top corners down to the roofline, and fold the resulting flaps over the roof sheathing (**Figure 5.18**). Before nailing it to the roof, run a bead of non-hardening mastic around the top edges of the support box to make a seal between it and the roof. Clean out any combustible material from inside the support box.

### 3. Class A Metal Chimney

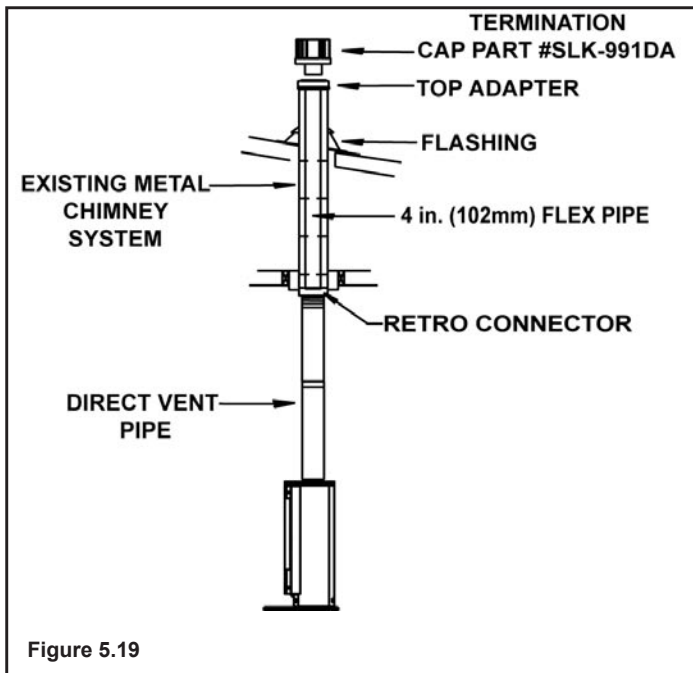


Figure 5.19

**NOTE:** Have the existing installation inspected by a qualified chimney sweep or professional installer prior to converting to direct vent. The existing chimney system must be in serviceable condition and functionally sound and clean.

#### Step 1.

Remove existing chimney cap.

#### Step 2.

Measure the distance from the top of the chimney to the bottom of the ceiling support box, add 3 in. (76mm) to this measurement, and cut a section of 4 in. (101mm) flex pipe to that length (the flex should be extended to its nominal length).

#### Step 3.

Connect the end of the flex pipe section to the underside of the top adapter, using four sheet metal screws (Figure 5.20).

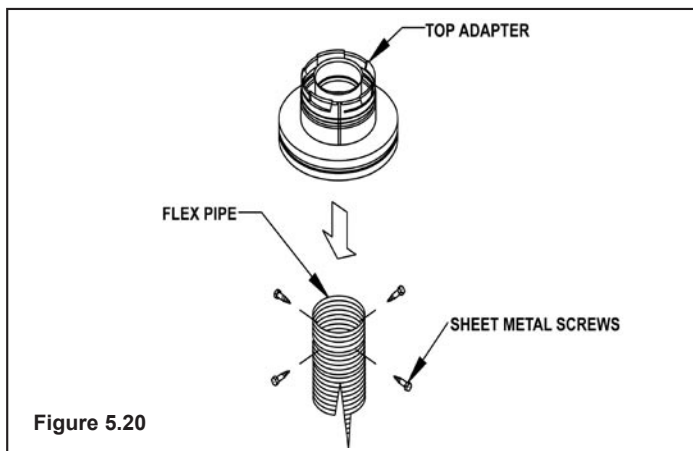


Figure 5.20

#### Step 4.

Pass the flex pipe down through the center of the chimney system, and center the top adapter on the top of the chimney pipe. Drill four 1/8 in. (3mm) diameter holes through the top adapter, and into the chimney top. Ensure that you are drilling into the metal on the chimney. Twist lock the high wind termination cap onto the top adapter (Figures 5.21 and 5.22).

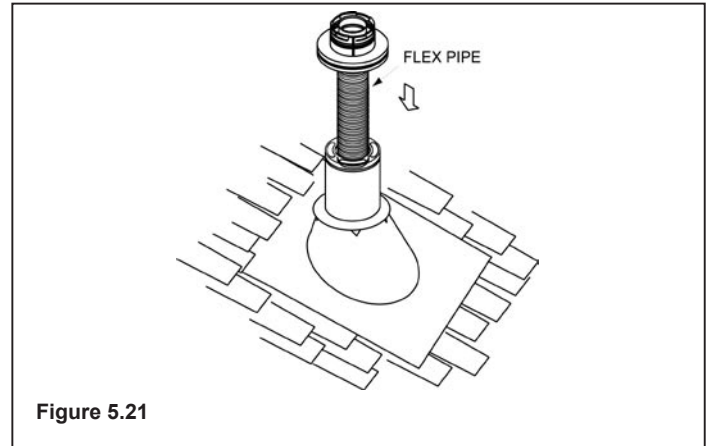


Figure 5.21

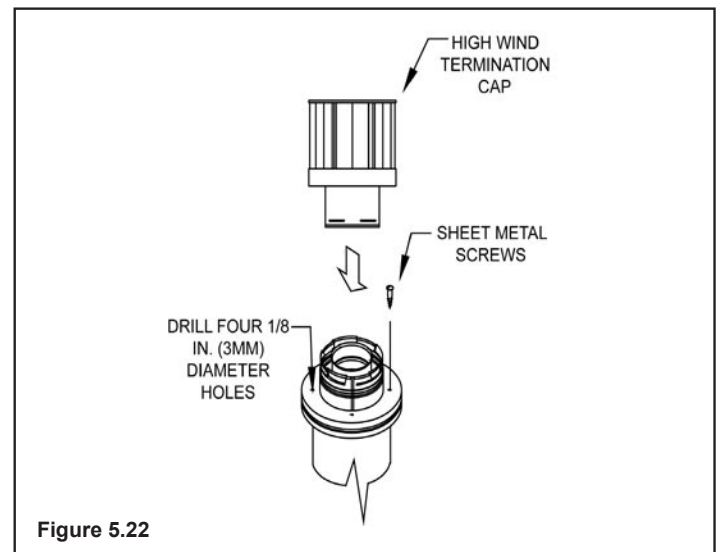


Figure 5.22

#### Step 5.

Pull the flex pipe down through the ceiling support box, until it protrudes approximately 3 in. (76mm). Connect the flex pipe to the retro connector, and attach with sheet metal screws.

#### Step 6.

Push the flex pipe back up into the ceiling support box, center the retro connector, and attach it to the support box with sheet metal screws.

#### Step 7.

The connection between the appliance and the retro connector may be completed with sections of direct vent pipe.

## 4. Existing Masonry Chimney

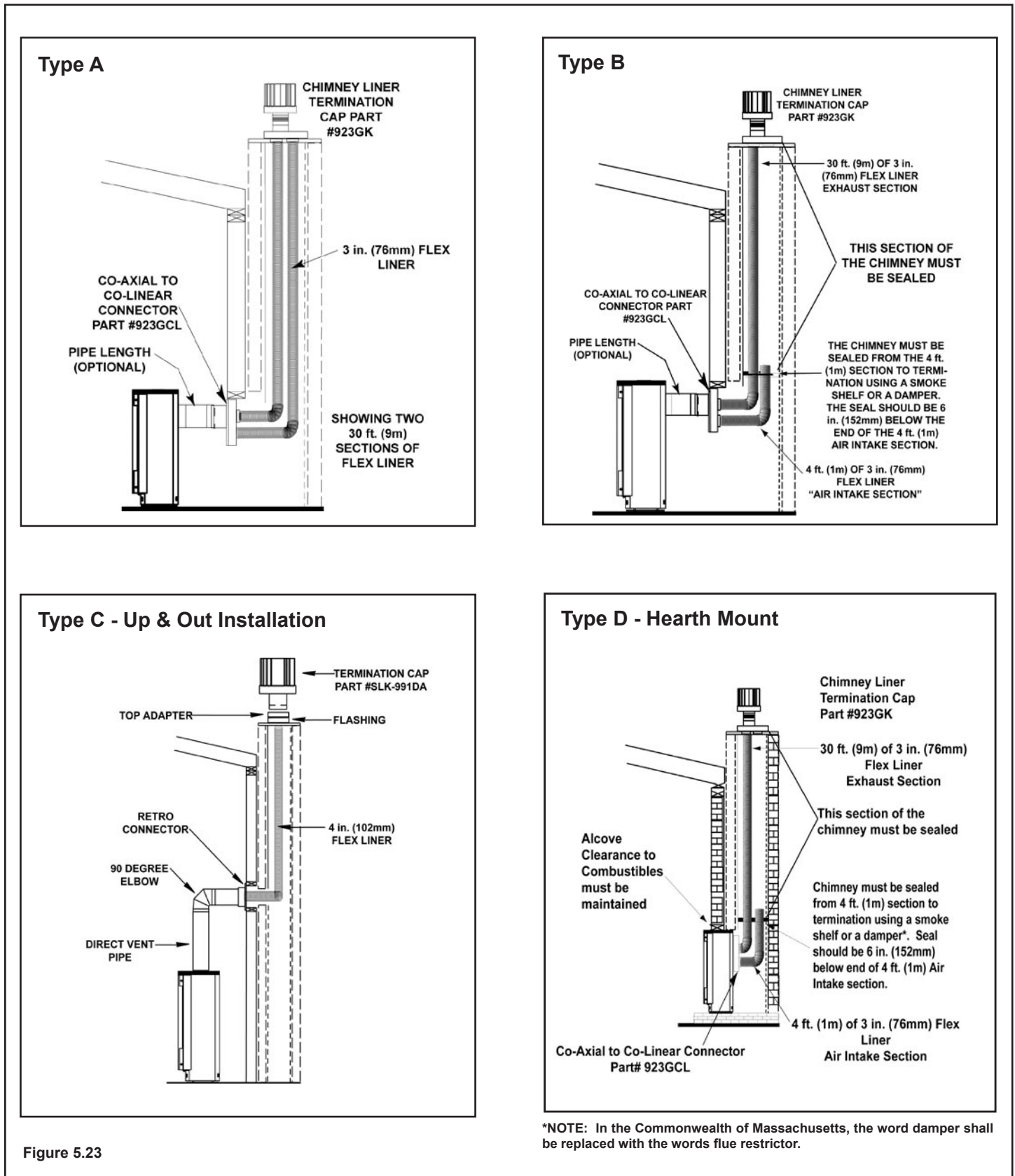


Figure 5.23

\*NOTE: In the Commonwealth of Massachusetts, the word damper shall be replaced with the words flue restrictor.

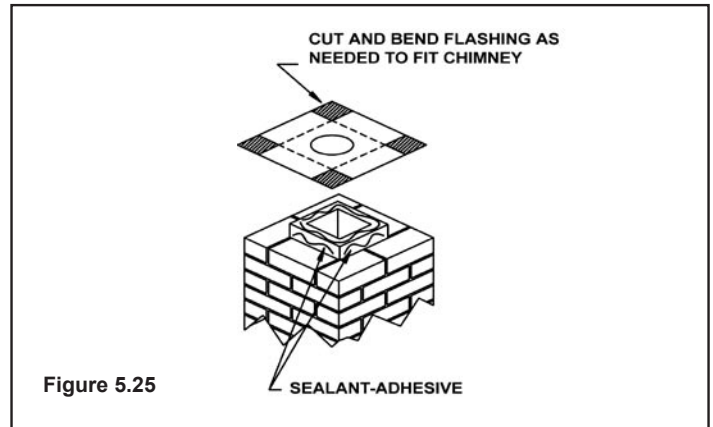
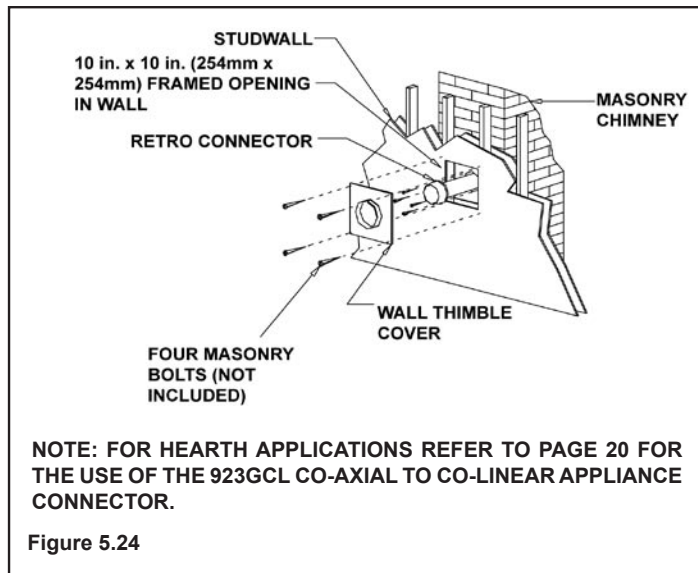
## 4. Existing Masonry Chimney-(Cont'd)

### Step 1.

Before cutting any holes, assemble the desired sections of direct vent pipe to determine the center of the masonry penetration.

### Step 2.

Once the center point of the penetration has been determined, cut a 6 in. (152mm) diameter hole in the masonry. If the hole is too large, the retro connector might not mount properly; if the hole is too small, the appliance might starve for intake air. If there is a frame wall in front of the masonry wall, cut and frame a 10 in. (254mm) square opening in the wall (centered around the 6 in. (152mm) masonry opening). If there is sheet rock only (no studs) in front of the masonry the 10 in. (254mm) opening is still needed, but does not need to be framed. If the hole is framed a wall thimble is required. This allows the retro connector to mount directly on the masonry and provide the correct clearances to combustibles (**Figure 5.24**).



### Step 4.

To determine the length of flex needed, measure from 3 in. (76mm) above the top of the flashing down to the level of the opening. Add the distance from the center of the chimney out through the wall. Cut a piece of 4 in. (102mm) flex to this length (extended to its nominal length). Be sure to leave 2 in.-3 in. (51mm-76mm) of flex above the existing chimney to allow for connection to the termination kit.

### Step 5.

Connect the flex liner to the top adapter using three sheet metal screws (**Figure 5.20**, page 19).

### Step 6.

Feed the flex liner through the flashing into the chimney. Carefully feed the flex liner down the chimney to the bottom and out the opening in the masonry wall, forming an angle to line up the flex liner with the vent opening on the appliance.

**WARNING: Do not let the flex liner sag below the level at which it will connect to the appliance or connector. This could allow hot gas to become trapped and potentially become a fire hazard. The flex liner path should always be sloped up toward the termination cap.**

### Step 7.

If additional lengths of flex liner are needed to span the chimney height, use a flex coupler to connect the pieces of flex liner together. Connect the flex to the coupler by using four sheet metal screws for each side (**Figure 5.26**, on page 22).

## WARNING

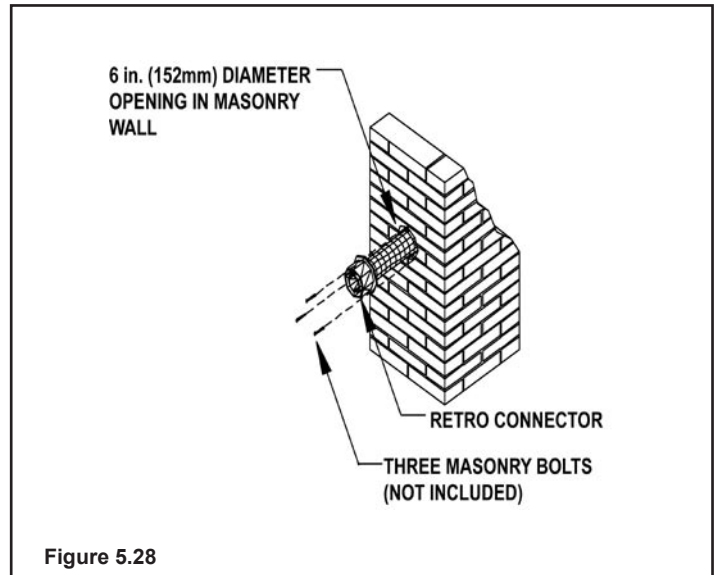
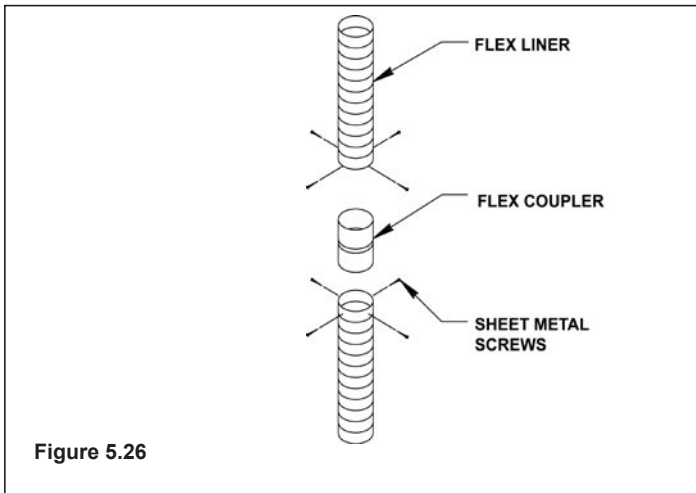
Fire Risk.  
Explosion Risk.

- Do not let the flex liner sag below the level at which it will connect to the appliance or connector. This could allow hot gas to become trapped and potentially become a fire hazard. The flex liner path should always be sloped up toward the termination cap.

### Step 3.

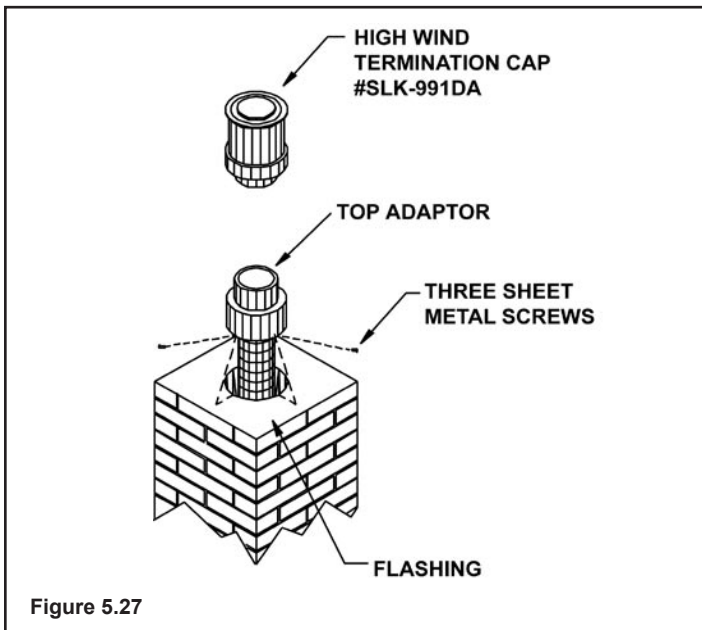
Secure the flashing to the top of the masonry chimney using a bead of non-hardening sealant-adhesive. If the flashing is larger than the top of the chimney, cut and fold flashing as needed to fit chimney (**Figure 5.25**).

#### 4. Existing Masonry Chimney- (Cont'd)



#### Step 8.

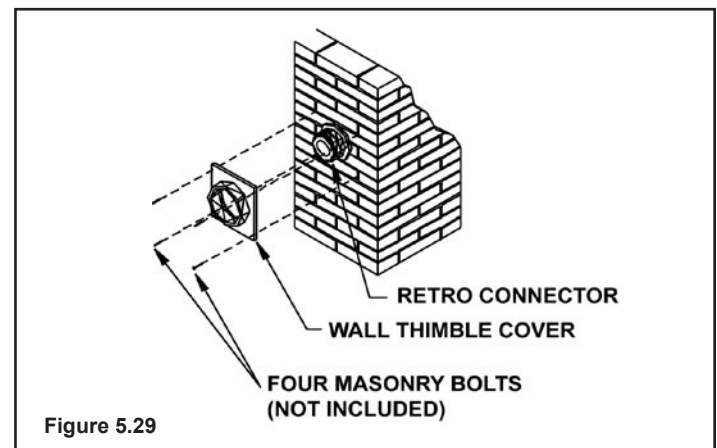
Secure the top adapter to the flashing. Use three sheet metal screws through the side of the top adapter into the flange on the flashing (**Figure 5.27**). Twist lock the high wind termination cap onto the top adapter.



wall in front of the masonry, use wood screws to mount wall thimble cover to framed wall, over retro connector and 10 in. (254mm) square framed opening (**Figure 5.24**, page 21). If needed, add a section of direct vent pipe to the retro connector in order to extend through the opening in the wall thimble cover.

#### Step 11.

The connection between the appliance and the retro connector may be completed with sections of direct vent pipe.



#### Step 9.

Attach the flex to the retro connector. Use three sheet metal screws to attach the flex liner to the connector (**Figure 5.28**). Mount the retro connector to the masonry wall using masonry bolts. Redrill larger holes on connector as needed. Be careful to ensure that the connector is centered in the opening and the mounting holes line up with the masonry wall.

#### Step 10.

Slide wall thimble cover over retro connector and secure with masonry bolts (**Figure 5.29**). If you have a framed

**WARNING:** If any other appliances have been previously attached to this masonry flue or an open appliance, etc., all openings into flue should be sealed properly. It is very important that there is only one appliance on a vent system and that there are no air leaks into the masonry chimney itself other than the vent appliance venting.

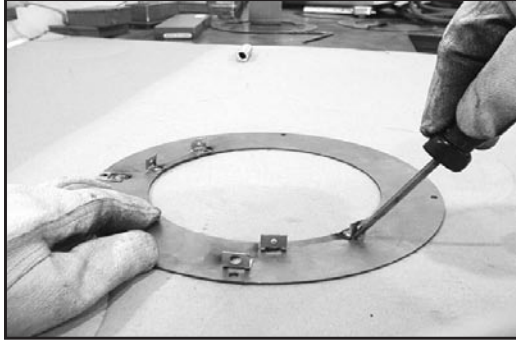
**WARNING:** Failure to position the parts in accordance with these diagrams or failure to use only parts specifically approved with this appliance may result in property damage or personal injury.

## H. Slim Line Wall Thimble

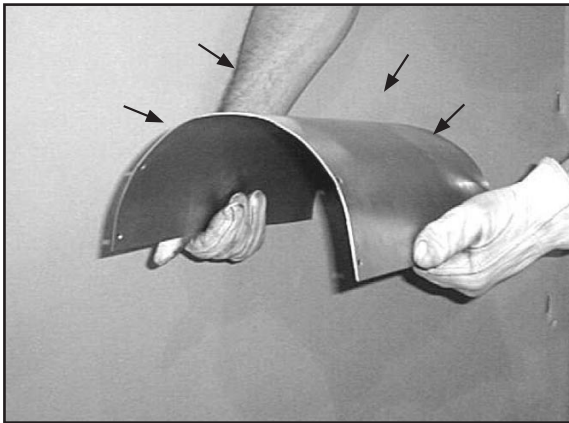
### BEFORE YOU BEGIN:

Review the venting configurations in **Figures A, B and C** on the next page.

### 1. Assembling Slim Line Trim Ring and Heat Shield

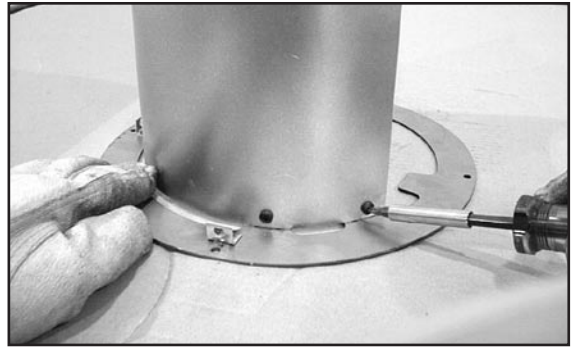


**Figure 5.30** Lay the trim ring on flat surface and bend up the six welded brackets into a 90 degree position. The brackets along the outer edge of the ring are for locating the ring in the center of the hole.



**Figure 5.31** The heat shield is shipped flat and must be hand bent into a half circle before attaching it to the trim ring. Bend the heat shield as shown.

**NOTE:** Wear leather gloves when bending the heat shield to prevent injury.

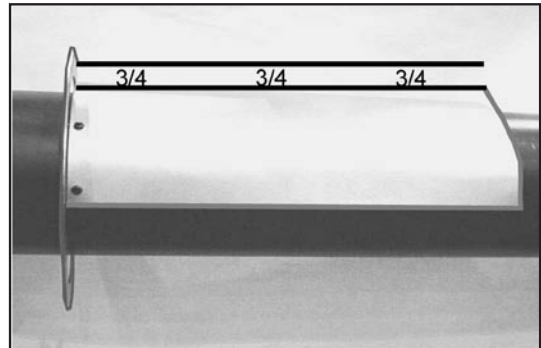


**Figure 5.32** Attach the heat shield to the trim ring with the four screws provided. Screws go through the heat shield and into the brackets on the trim ring.

### 2. Installing Slim Line Trim Ring and Heat Shield

Measure from the floor to the center of the vent pipe. Cut out a 9-1/2 in. (241mm) hole in the wall. Hold the trim ring/heat shield assembly in place and put a mark on the shield with a black marker where it protrudes through the exterior wall. See Figure A on the next page.

Use that mark as a guide to trim off excess heat shield with a pair of sheet metal shears.



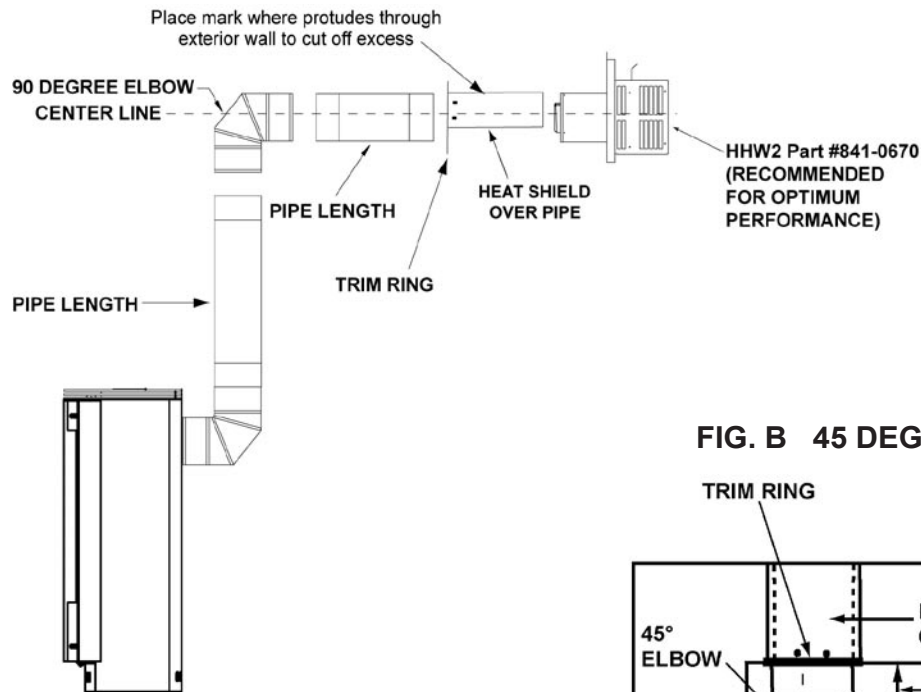
**Figure 5.33** When installing the trim ring/heat shield assembly make sure the trim ring is centered in the hole and that the shield is above the pipe. There must be a minimum of 3/4 in. (19mm) minimum clearance maintained to combustibles from the top of the heat shield.

Ensure that framing on the inside of the wall is a minimum inner framing diameter of 10 in. x 10 in. (254mm x 254mm).

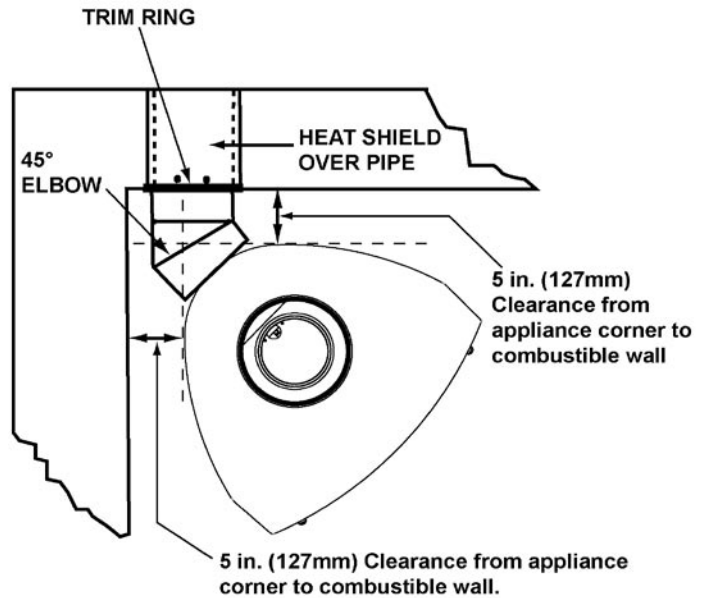
The four trim ring mounting screws provided should be replaced with appropriate fasteners for stucco, brick, concrete, or other types of sidings.

## H. Slim Line Wall Thimble- (Cont'd)

**FIG. A 90 DEGREE ELBOW**



**FIG. B 45 DEGREE ELBOW**



**FIG. C MINIMUM CLEARANCE**

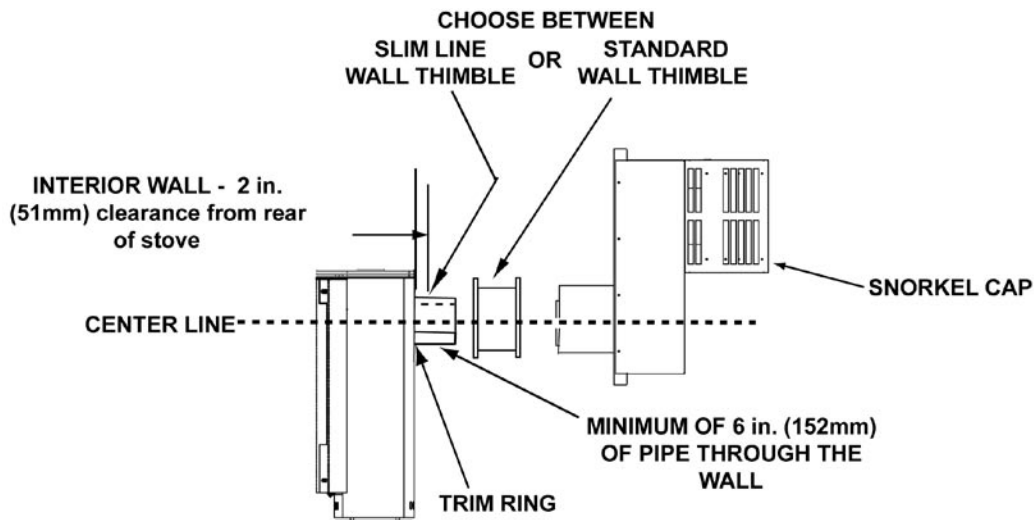


Figure 5.34

# 6

## Gas Information

### A. Fuel Conversions

Before making gas connections ensure that the appliance being installed is compatible with the available gas type.

Any natural or propane gas conversions necessary to meet the appliance and locality needs must be made by a qualified technician using Hearth & Home Technologies specified and approved parts.

#### 1. Converting to LP Gas

##### WARNING!

This conversion kit shall be installed by a qualified service agency in accordance with the manufacturer's instructions and all applicable codes and requirements of the authority having jurisdiction. (In the Commonwealth of Massachusetts installation must be performed by a licensed plumber or gas fitter.) If the information in these instructions is not followed exactly, a fire, explosion or production of carbon monoxide may result causing property damage, personal injury or loss of life. The qualified service agency is responsible for the proper installation of this kit. The installation is not proper and complete until all the operation of the converted appliance is checked as specified in the manufacturer's instructions supplied with the kit.

Any damaged valve components should not be installed. If a valve or regulator has been dropped or appears to have been modified, the valve or regulator should not be installed.

**TOOLS REQUIRED:** #2 Phillips head screwdriver; Power drill (a 90° drill is helpful); Tamper-resistant Torx Driver TR20; #2 Phillips bit; 5/32 in. (4mm) Allen wrench; 3/8 in. (10mm) open end wrench.

Conversion component list:

- LP Burner orifice: #52DMS
- Pilot orifice
- Gas valve regulator
- Propane conversion plate
- LP label

**CAUTION: THE GAS SUPPLY SHALL BE SHUT OFF PRIOR TO DISCONNECTING THE ELECTRICAL POWER BEFORE PROCEEDING WITH THE CONVERSION.**

#### PROCEDURE FOR CONVERSION:

1. Turn off gas to appliance by closing the inlet line valve.
2. Turn off power to the module and valve.

3. Remove the front door assembly, inner glass door assembly and logs.
4. To remove the burner, loosen the front screw on the pilot bracket. Slide the tab on the left side at the back of the burner out from under the pilot bracket, and out of the firebox. (Fig. 6.1)

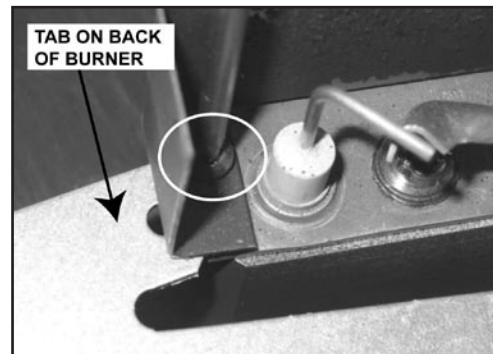


Figure 6.1

5. Remove the inlet gas line from valve connection.
6. Remove the six hold down screws from the firebox bottom plate.
7. Disconnect the orange and green wires from the control valve and lift the bottom plate and valve assembly from the appliance.
8. Remove the orange and white wires from the igniton module which is located on the control panel (see Figure 7.1 on page 30).
9. Using a #20 tamper-proof Torx, remove the regulator and rubber gasket on face of valve (see Figure 6.2). Discard both the regulator and gasket.
10. Install the new regulator along with the new rubber gasket included in the conversion kit (see Figure 6.2).

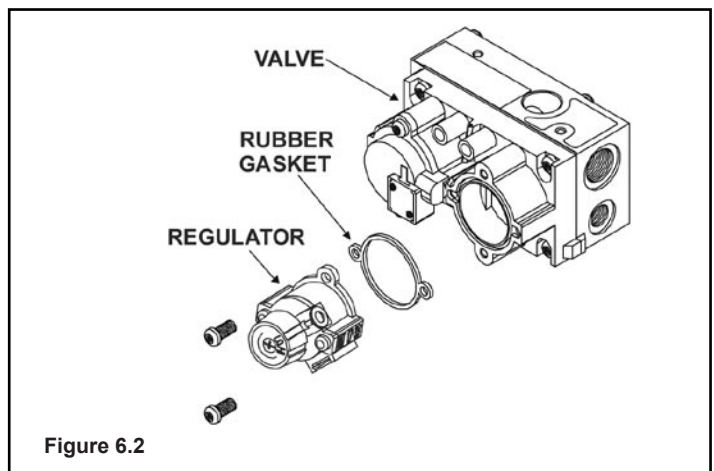


Figure 6.2

## WARNING



Fire Risk.  
Explosion Risk.  
Gas Leak Risk.

- Rubber gasket must be seated properly on valve face.
- Do not install a valve or regulator that has been dropped.



11. Using a 3/8 in. (10mm) nut driver or wrench, remove the NG orifice and replace it with the LP orifice provided in this kit (see **Figure 6.3**).



Figure 6.3

12. Unscrew the pilot tube fitting on the pilot and replace the orifice spud with the one included in the conversion kit (see **Figure 6.4**).

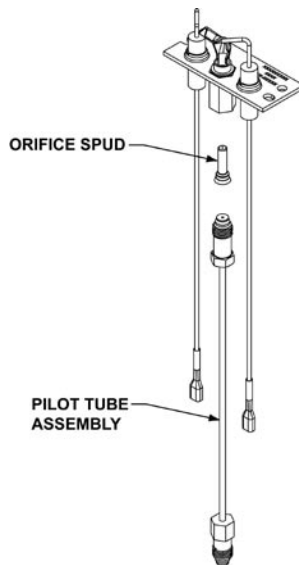


Figure 6.4

13. Place the round LP label on the bottom base pan. Place the propane conversion plate adjacent to the existing rating plate.

**NOTE:** The qualified service agency installing this conversion **MUST** enter the day, month, and year, and sign the propane conversion plate added to the appliance.

14. Reinstall the bottom plate and valve assembly into the appliance. Reinstall the six hold down screws.
15. Reconnect the inlet gas line to the valve assembly and turn on the gas line valve. Check the incoming line for leaks.
16. Reconnect the electrical power supply.
17. Reconnect the orange wire to the valve assembly. This will allow for the pilot to turn on with the control switch in the "ON" position. Check all pilot line connections for leaks. (See **Figure 6.4**)
18. Use a commercially available, non-corrosive leak check solution to test for leaks around the pilot. Be sure to rinse off all leak check solution following testing. See **Figure 6.4** for leak check points. Extinguish the pilot.



## WARNING

Shock or burn risk.

- Disconnect green wire from gas valve. Failure to disconnect green wire could result in severe burns.

19. Reinstall the green wire on the valve.
20. Before reinstalling the burner, ensure that the shutter setting is fully open. Slide the tab on the left side at the back of the burner under the pilot bracket. (see **Figure 6.5**). Retighten the screw.

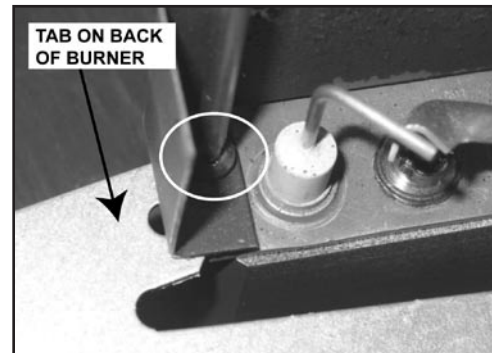



Figure 6.5


21. Light the pilot and burner and use a commercially available, non-corrosive leak check solution to test for leaks. Be sure to rinse off all leak check solution following testing and prior to placing the appliance into operation. Extinguish the pilot and burner.
22. Reinstall the logs by following the log placement instructions.
23. Reinstall the inner glass door assembly and the front door assembly.
24. Turn on the appliance to check for proper burner flame pattern.
25. Verify that the signed and dated conversion plate has been added to the appliance.

## 1. Converting to LP Gas - (Cont'd)

### Verify the performance of the ignition system:

1. Verify pilot sparks, pilot lights, pilot stops sparking, and the main burner turns "ON".
2. Turn the appliance "OFF". Verify that both the pilot and burner turn "OFF".
3. Repeat Step 1 above.
4. With the burner "ON", remove the green wire connected to the valve. The main burner should shut "OFF".
5. Reattach the green wire to the valve, and the main burner should turn back "ON".
6. With the main burner "ON", remove the orange wire connected to the valve. The pilot and burner should go out, and the pilot will start to spark.
7. Turn the appliance "OFF" and reattach the orange wire to the valve.



**WARNING**




Fire Risk.  
Explosion Risk.

- If the information in these instructions is not followed exactly, a fire, explosion or production of carbon monoxide may result causing property damage, personal injury or loss of life.

The qualified service agency is responsible for the proper installation of this conversion kit. The installation is not proper and complete until the operation of the converted appliance is checked as specified in the manufacturer's instructions supplied with the kit.


**WARNING**





Fire Risk.  
Explosion Risk.

- Disconnect any electrical cords and turn off gas supply to appliance before proceeding if converting fuel on an appliance already fully installed.

## B. Gas Pressures


Proper input pressures required for optimum appliance performance, gas line sizing requirements need to be followed from NFPA51.



**WARNING**



Fire Risk.  
Explosion Hazard.  
High pressure will damage valve.

- Disconnect gas supply piping BEFORE pressure testing gas line at test pressures above 1/2 psig.
- Close the manual shutoff valve BEFORE pressure testing gas line at test pressures equal to or less than 1/2 psig.


**WARNING**



Verify inlet pressures.

- High pressure may cause overfire condition.
- Low pressure may cause explosion.
- Verify minimum pressures when other household gas appliances are operating.

Install regulator upstream of valve if line pressure is greater than 1/2 psig.

Pressure requirements for appliance are shown in the table below. Minimum pressures must be met when other household gas appliances are operating.

PRESSURE	NG	LP
Minimum Inlet Pressure	5 inches w.c.	11 inches w.c.
Maximum Inlet Pressure	7 inches w.c.	14 inches w.c.
Manifold Pressure on "HI"	3.5 inches w.c.	10 inches w.c.

If the pressure is not sufficient, ensure:

- 1) the piping used is large enough.
- 2) the supply regulator is adequately adjusted.
- 3) that the total gas load for the residence does not exceed the amount supplied.

The supply regulator (the regulator that attaches directly to the residence inlet or to the propane tank) should supply gas at the suggested input pressure listed above. Contact the local gas supplier if the regulator is at an improper pressure.

## C. Gas Connection

**NOTE:** Have the gas supply line installed in accordance with local building codes, if any. If not, follow ANSI Z223.1. Installation should be done by a qualified installer approved and/or licensed as required by the locality. (In the Commonwealth of Massachusetts, installation must be performed by a licensed plumber or gas fitter.)

**NOTE:** A listed (and Commonwealth of Massachusetts approved) 1/2 inch (13mm) T-handle manual shut-off valve and flexible gas connector are connected to the 1/2 inch (13mm) control valve inlet.

- **If substituting for these components, please consult local codes for compliance.**

### WARNING



Gas Leak Risk.

- Support control when attaching pipe to prevent bending gas line.

**NOTE:** The gap between the supply piping and gas access hole may be plugged with non-combustible insulation to prevent cold air infiltration.

Leak test all gas line joints and the gas control valve prior to and after starting the appliance.

Before making the gas connection, ensure that the appliance you are installing is designed for the type of gas being supplied. This information can be found on the ratings label under the appliance. If the appliance has been converted to propane (LP), the valve cover should have a label stating that the appliance has been converted to propane.

Connect the gas line at the 3/8 in. (10mm) pipe connector on the valve at the back of appliance. We recommend connecting the appliance with an approved flex gas line. If flex gas lines are not approved in your area, you must connect a hard pipe to the gas hookup.

You must supply a manual shut-off valve in a visible location within 3 ft. (914mm) of the appliance.

### WARNING



Fire Risk or Explosion Hazard.

- Gas build-up during line purge may ignite.
- Purge should be performed by a qualified technician.
- Ensure adequate ventilation.
- Ensure there are no ignition sources such as sparks or open flame.



- A small amount of air will be in the gas supply lines. When first lighting appliance it will take a short time for air to purge from lines. When purging is complete the appliance will light and operate normally.

Air only needs to be purged again if gas valve has been turned to the OFF position.

### WARNING



CHECK FOR GAS LEAKS

Explosion Risk.

Fire Risk.

Asphyxiation Risk.

- Check the fittings and connections
- Do not use open flame.
- After the gas line installation is complete, all connections must be tightened and checked for leaks with a commercially-available, non-corrosive leak check solution. Be sure to rinse off all leak check solution following testing. Fittings and connections may have loosened during shipping and handling.



### WARNING



Fire hazard.

Do NOT change the valve settings.

- This valve has been preset at the factory.
- Changing valve settings may result in fire hazard or bodily injury.

### HIGH ALTITUDE INSTALLATIONS

Omni-Test Laboratories, Inc. listed gas appliances are tested and approved without requiring changes for elevations from 0 to 2000 feet in the U.S.A. and 0 to 4500 feet in Canada.

When installing this appliance at an elevation above 2000 feet, it may be necessary to decrease the input rating by changing the existing burner orifice to a smaller size. Input rate should be reduced by 4% for each 1000 feet above a 2000 foot elevation in the U.S.A. If the heating value of the gas has been reduced, these rules do not apply. To identify the proper orifice size, check with the local gas utility.

If installing this appliance at an elevation above 4500 feet (in Canada), check with local authorities.

# 7


## Electrical Information

### A. Recommendation for Wire

See B5 below for recommended maximum lead length (two wire) when using wall thermostat/switch.


**NOTE:** This appliance must be electrically wired and grounded in accordance with local codes or, in the absence of local codes, with **National Electric Code ANSI/NFPA 70-latest edition** or the **Canadian Electric Code, CSA C221.1**.

### B. Connecting to the Appliance

**WARNING**

Wire 110V to electrical junction box..  
Do NOT wire 110V to valve.  
Do NOT wire 110V to wall switch

- Incorrect wiring will damage millivolt valves.
- Incorrect wiring will override IPI safety lockout and may cause explosion.



1. This appliance may be used with a wall switch, wall mounted thermostat and / or a remote control
2. If using thermostat, use one compatible with a millivolt gas valve system.
3. Follow parameters for locating thermostat (see individual thermostat instructions) to ensure proper operation of appliance.
4. Use low resistance thermostat wire for wiring from ignition system to the wall switch and thermostat.
5. Use the following chart for wire sizing.


Wire Size	Max. Length
16 gauge	65 feet
18 gauge	40 feet
20 gauge	25 feet
22 gauge	18 feet

6. Keep wire lengths as short as possible by removing any excess wire length.
7. Low voltage and 110 VAC voltage cannot be shared within the same wall box.
8. Ensure the thermostat is mounted level for accurate readings.

9. The thermostat should be mounted on an inside wall and not in direct line with the appliance convection air.
10. If the thermostat is located too close to the appliance, you may need to set the temperature setting slightly higher to maintain the desired temperature in your home.

**Do not connect this appliance to a thermostat serving any other appliance.**

**Bedroom installation in Canada requires this appliance to be connected to a thermostat.**

**WARNING**

Shock hazard.

- This appliance is equipped with a three pronged (grounding) plug for your protection against shock hazard and should be plugged directly into a properly grounded three prong receptacle. Do not cut or remove the grounding prong from this plug.

### C. IntelliFire® Ignition System Wiring

This appliance requires a 110 VAC supply to the appliance junction box for operation. A wiring diagram is shown in **Figure 7.1** on page 31.

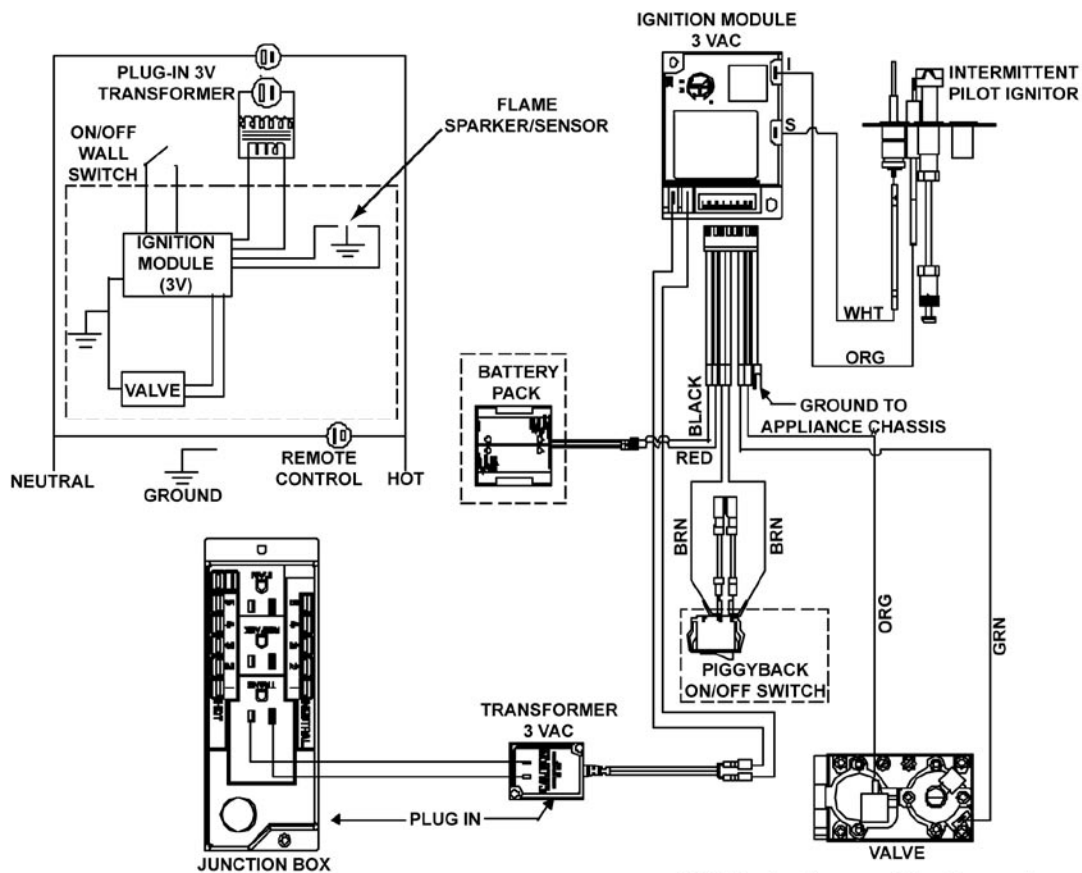
This appliance is equipped with an IntelliFire® control valve which operates on a 3 volt system.

This appliance is supplied with a 3 volt AC transformer, which requires the installation of the supplied junction box.

This appliance is supplied with a battery pack that requires two D cell batteries (not included). Batteries cannot be placed in the battery pack while using the 3 volt AC transformer. Conversely, the transformer must be unplugged if the battery pack is used.

**CAUTION**

Battery polarity must be correct or module damage will occur.



NOTE: Appliance will not operate unless properly grounded.

Figure 7.1

### CAUTION

Label all wires prior to disconnection when servicing controls. Wiring errors can cause improper and dangerous operation. Verify proper operation after servicing.



### CAUTION

- Shock hazard.
- Replace damaged wire with type 105° C rated wire.
- Wire must have high temperature insulation.

## D. Loss of Power and Battery Backup Usage

1. Disconnect the power supply.
2. Remove the front door assembly and lower access panel.
3. Place two "D" cell batteries into the battery holder. (Figure 7.2)
4. Turn on appliance and verify it is operational.
5. Replace lower access panel and front door assembly.

### CAUTION

- If IPI battery back-up is installed:
- Do not install batteries if the backup mode may not be used for extended time.
  - Batteries may leak.
  - Install batteries only when needed for power outage.

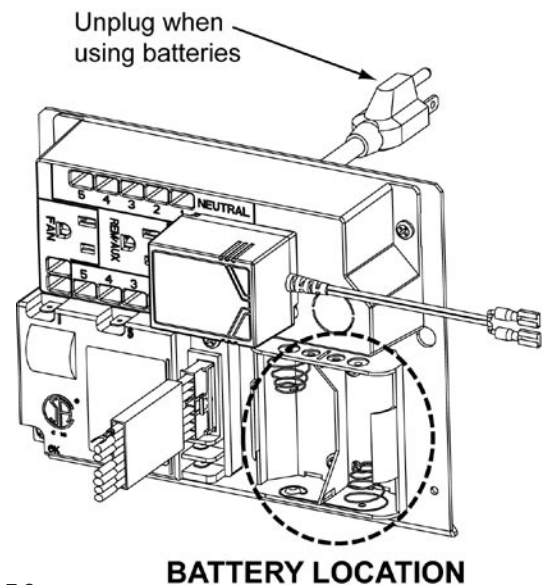


Figure 7.2

# 8

## Appliance Setup

### A. Remove Shipping Materials

Remove shipping materials from inside or underneath the firebox.

Do not remove the ignitor shield on the pilot assembly until set up is complete. (**Figure 8.1**)

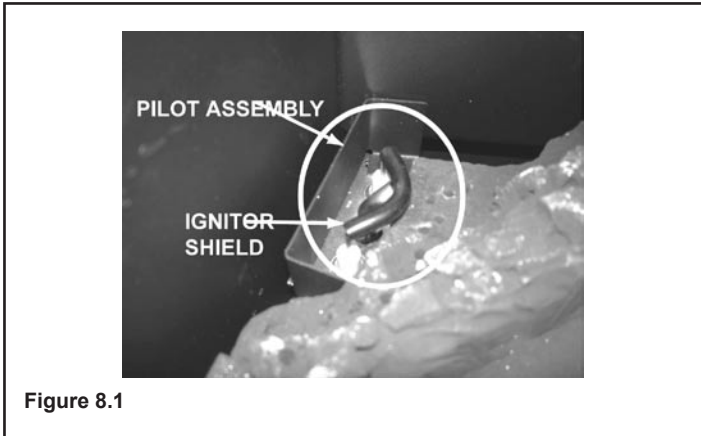


Figure 8.1

Gas line and power cord are shipped inside back panel. To access the gas line and power cord, remove the top plate from the appliance. Remove and retain the two Allen head screws that hold the back panel in place. Refer to **Figure 8.6**, page 32.

Using the black grommet located in the component bag, slide it into the bottom of the back panel and feed the power cord through the grommet, as shown in **Figure 8.2**.

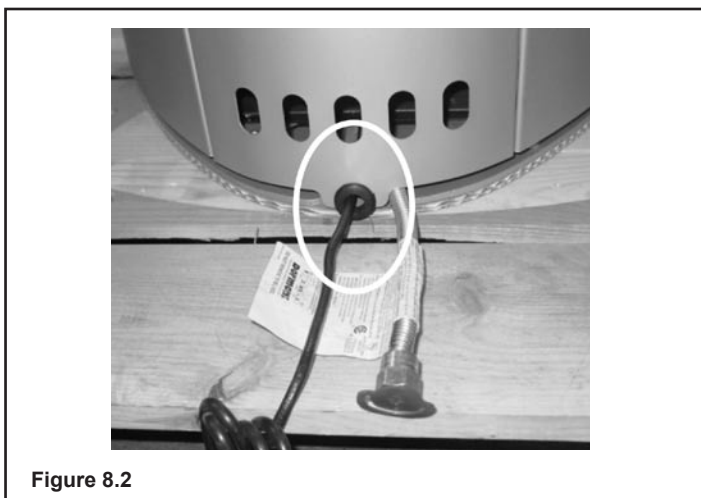


Figure 8.2

### B. Unbolting Appliance from the Pallet

The appliance is bolted and screwed to the pallet for shipping. Use a 1/2 in. socket to remove the bolt in center of bottom plate. Use a Phillips screwdriver to remove the two screws in the front of the bottom plate and the two screws holding the metal strap across the back of the appliance. Refer to **Figure 8.3** for locations.

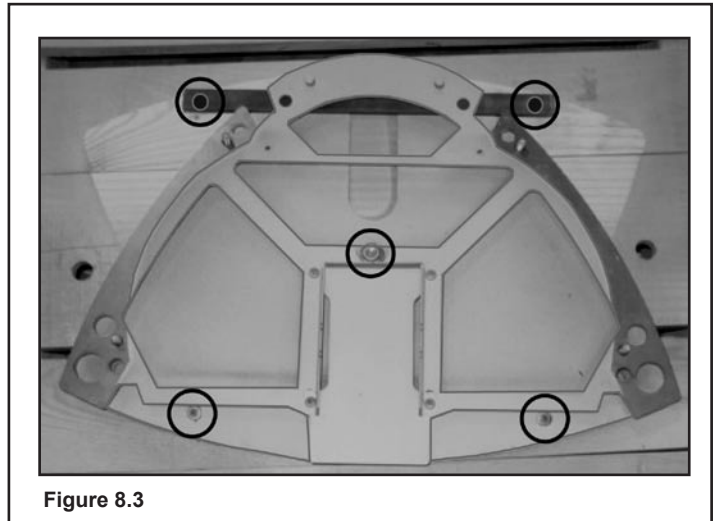



Figure 8.3

### C. Accessories

Install approved accessories per instructions included with accessories. Refer to Section 12 for appropriate accessories.

	<b>WARNING</b>
	<p>Shock or fire risk.</p> <p>Use <b>ONLY</b> optional accessories approved for this appliance.</p> <ul style="list-style-type: none"><li>• Using non-listed accessories voids warranty.</li><li>• Using non-listed accessories may result in a safety hazard.</li><li>• Only Hearth &amp; Home Technologies approved accessories may be used safely.</li></ul>

## D. Top to Rear Vent Conversion

When installing this appliance in a rear vent configuration with no vertical rise, a Snorkel Kit must be used.

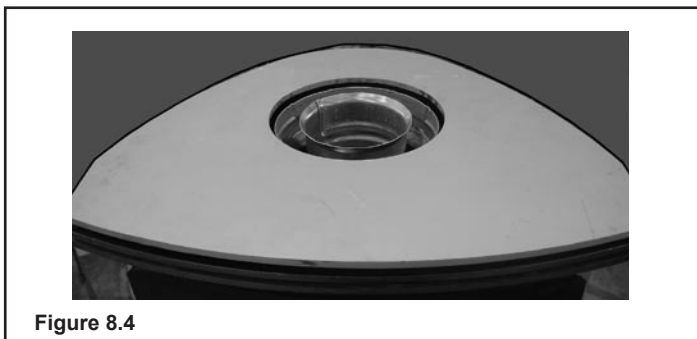
**KIT CONTENTS:** Top cover (no hole); Back panel (with hole).

**TOOLS REQUIRED:** Power drill; #2 Phillips bit; 5/32 in. (4mm) Allen wrench; 5/8 in. (16mm) open end wrench; high-temp silicone sealant (optional).

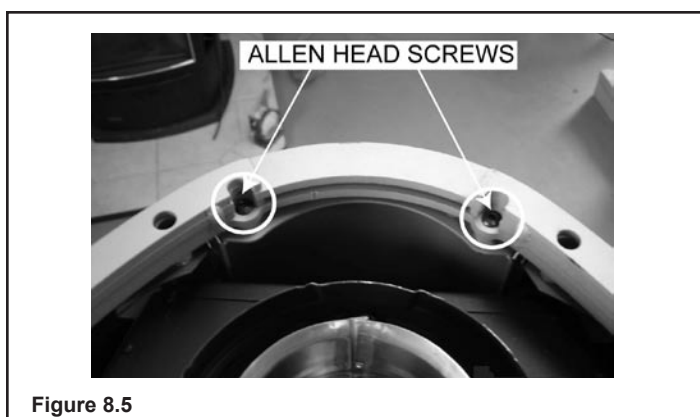
1. Remove the front door assembly by lifting it off of the spring-loaded latches on top of the appliance. Remove the inner glass door by disengaging the spring-loaded latches at the bottom of the appliance and lifting it off of the two spring loaded latches at the top of the appliance.

### ON TOP OF APPLIANCE:

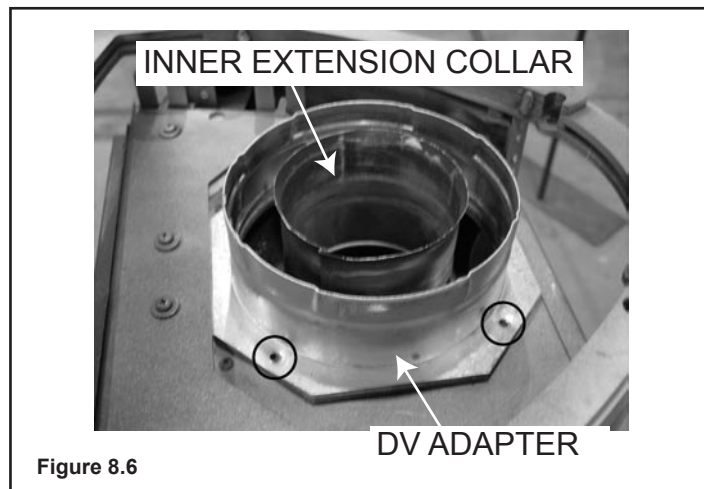
2. Remove the top plate with hole and discard. (Figure 8.4)



3. Remove and retain the Allen head screws that hold the solid back panel in place. (Figure 8.5) Remove and discard the solid back panel.



4. Remove the four screws from the DV adapter collar. (Figure 8.6) Set aside DV adapter collar and screws.
5. Remove the inner extension starter collar (Shown in Figure 8.6) and set aside.



### ON BACK OF APPLIANCE:

6. Remove the four screws from the cover plate on rear of appliance. Retain screws. (see Figure 8.7)



7. Install the outer collar with gasket to the rear of appliance with screws previously removed. Install the inner extension starter collar. (Figure 8.8)
8. Install the new back panel (with hole) to the rear of appliance. Replace the allen head screws removed in Step 3 to hold the back panel in place. (Figure 8.8)



### ON TOP OF APPLIANCE:

9. Install the cover plate removed from the rear of the appliance to the top of the appliance with the screws previously removed. (Figure 8.9)
10. Install the new solid top.

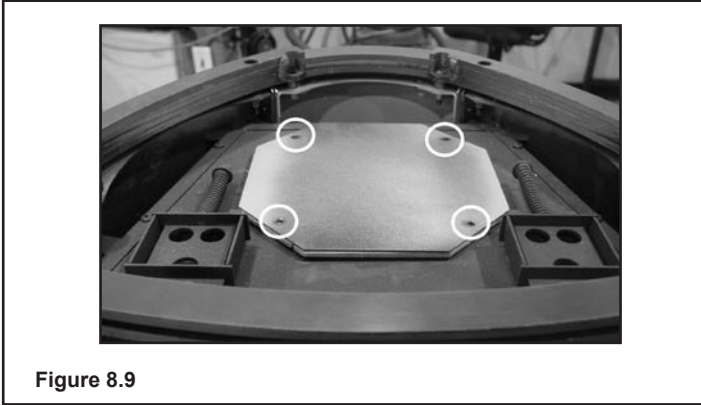


Figure 8.9

### E. Shutter Adjustment

The shutter is located on the underside of the burner, on the burner neck (see Figure 8.10).

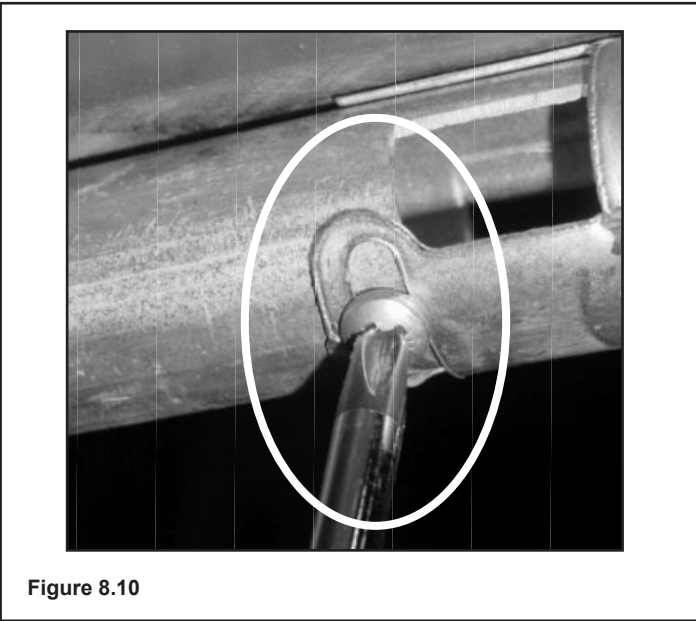


Figure 8.10

### F. Installing the Vent Restrictor

The vent restrictor plate must be installed before installing the baffle.

On the top of inside firebox for top vent, on back of firebox for rear vent, loosen the three screws out about 1/8 in.

Place the vent restrictor plate over the the screws and slide into locking position. Retighten the screws. (See Figure 8.11.)

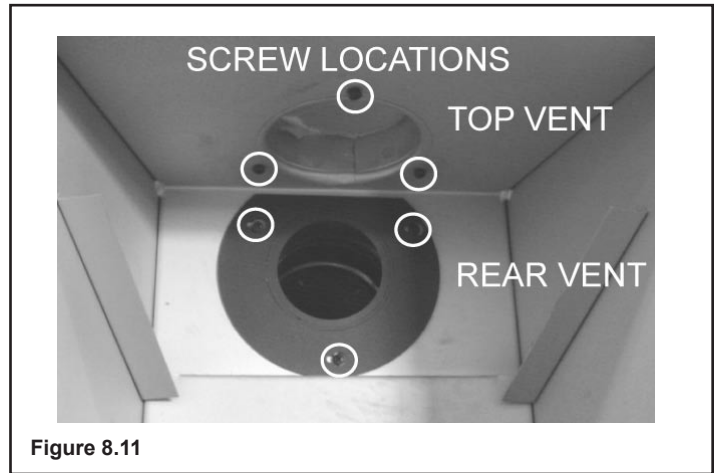


Figure 8.11

For vertical venting above 6 ft. a vent restrictor is required. After installing the vent restrictor plate, remove the inner rings as needed for proper flame height. (Refer to Figure 8.12.)

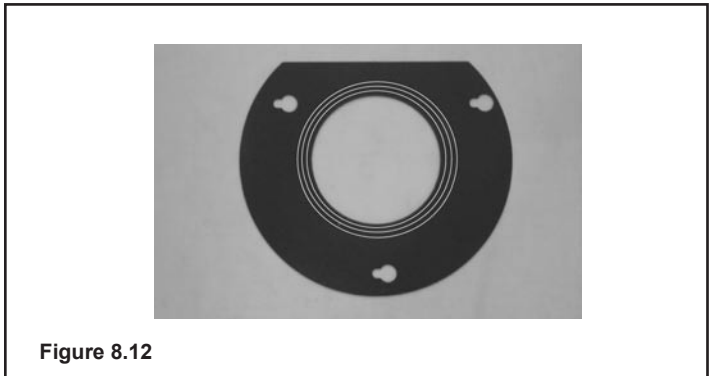


Figure 8.12

## G. Installing the Baffle

The baffle is shipped wrapped, inside the firebox. Install the baffle with the embedded "T" side up, place it on top of the brackets on the inside of the firebox, ensuring back edge of baffle makes contact with the back of the firebox.



Figure 8.13

## H. Lagging Down the Appliance Required

Place the lag bolt from the component bag in the center hole in the bottom plate (lagging clearance hole). The appliance must be lagged down securely to prevent tipping forward.

### WARNING



#### Tipping Risk

- Install appliance on a stable, level platform/ floor strong enough to support appliance without tipping.
- USE wood flooring, ceramic tile, brick hearth or high pressure laminate flooring applied directly over the sub-flooring material.

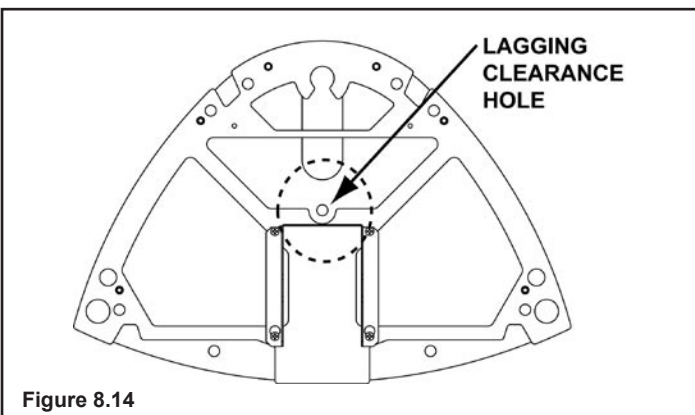


Figure 8.14

## I. Positioning the Logs

**REMOVE THE IGNITOR SHIELD FROM THE PILOT ASSEMBLY PRIOR TO INSTALLING THE LOGS. (Figure 8.15)**

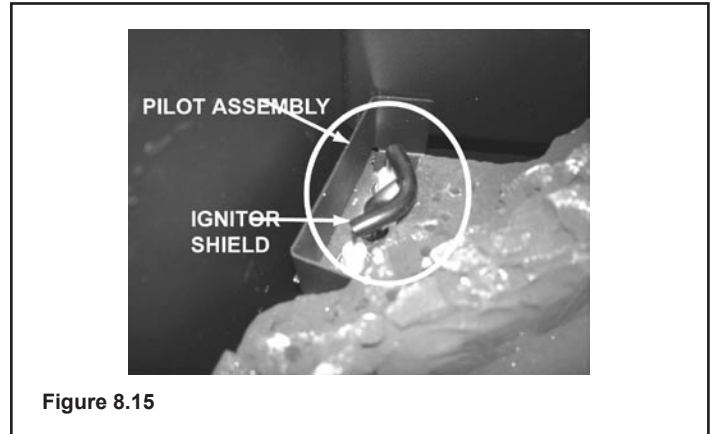


Figure 8.15

While still breakable, the logs do not become fragile until after the appliance is burned and they have cured. After curing, any handling must be done with care as breakage can easily occur.

**PLEASE NOTE: Logs have been designed to work specifically with the burner of this appliance. Exact placement will ensure proper operation of your gas appliance and reduce sooting.**



Figure 8.16 Place log #1 into the cradle in the burner. Lean the log back towards right corner of firebox.



**Figure 8.17** Locate log #2 over the pin in log #1 and into notch in log #1. Lean the log back toward the left corner of the firebox.

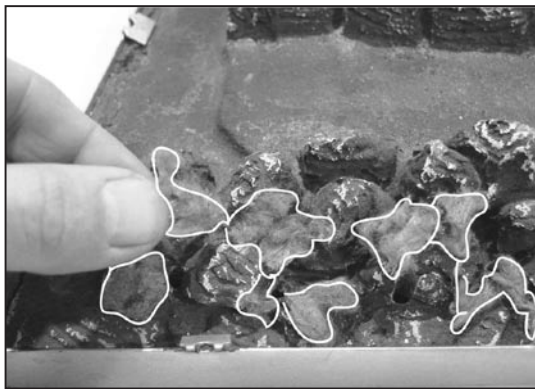
## J. Mineral Wool

**WARNING**

Explosion Risk.

- Follow ember placement instructions in manual.
- Do NOT place embers directly over burner ports.
- Replace ember material annually.

Improperly placed embers interferes with proper burner operation.



**Figure 8.18** Apply dime size pieces sparingly along front edge of burner. Do not completely block ports.

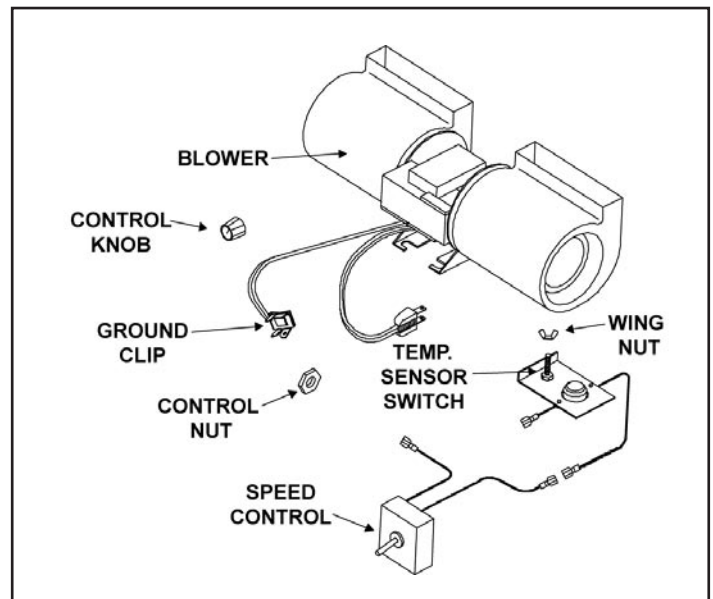
## K. Optional Blower

The GFK-160A Blower has been designed to circulate room air through the appliance to enhance heat output.

The GFK-160A blower system operates on 120 VAC, 60 Hz power. This is available through a receptacle in the factory installed junction box. The junction box is mounted in the bottom of the appliance behind the access panel. A variable speed control is provided with the blower system to provide quiet forced air flow at the desired speeds. A temperature sensor switch, which automatically turns the blower ON/OFF, is also provided with this kit.

**TOOLS REQUIRED:** Powered screwdriver with Phillips head bit; a flashlight is helpful.

## CHECK CONTENTS OF SHIPPING CARTON



**Figure 8.19** Compare CONTENTS OF CARTON with the actual parts received. If any parts are missing or damaged, contact your dealer before starting installation. Do not install a damaged blower kit.

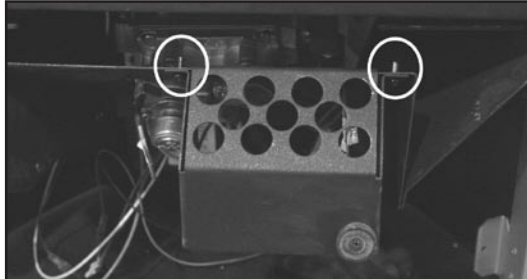
## INSTALLATION PRECAUTIONS

The GFK-160A Blower kit is tested and safe when installed in accordance with this installation manual. It is your responsibility to read all instructions before starting installation and to follow these instructions carefully during installation to assure maximum benefit from, and safe operation, of the blower.

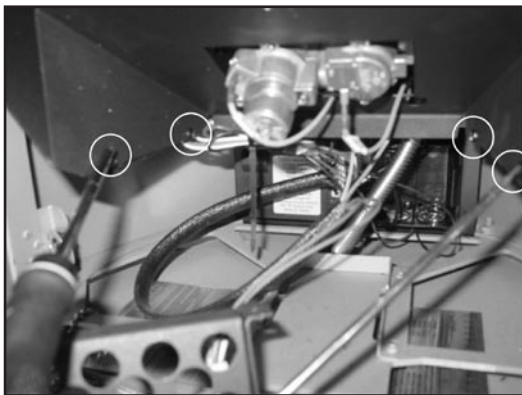
This blower is carefully engineered and must be installed only as specified. If you modify it or any of its components, you may cause a fire hazard and will void the WARRANTY. In addition, such action may void the coverage provided by the owner's home insurance.

**CAUTION:** All wiring should be done by a qualified electrician and shall be in compliance with local codes and with the National Electric Code ANSI/NFPA NO. 70-current (in the United States), or with the current CSA C22.1 Canadian Electric Code (in Canada).

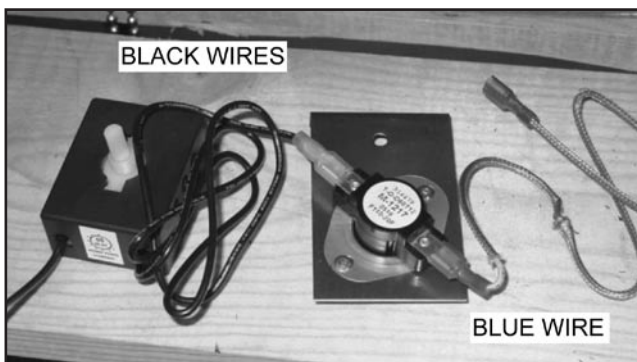
**WARNING: DO NOT CONNECT 110-120 VAC WIRING TO THE GAS CONTROL VALVE OF THIS APPLIANCE.**



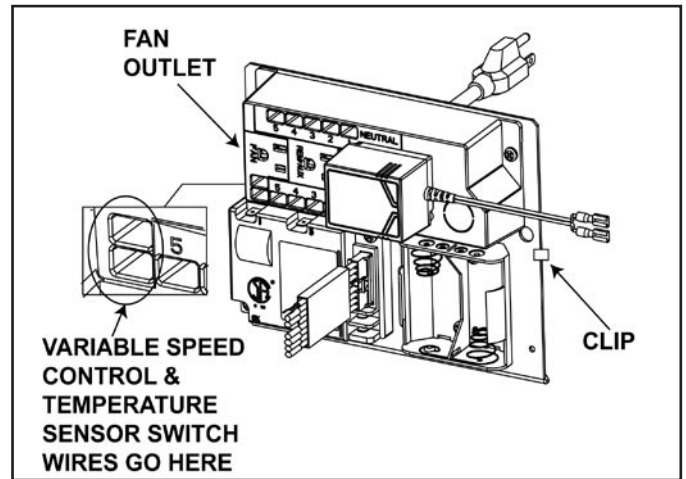
**Figure 8.20** Disconnect all electrical power. Remove the front door assembly by lifting off of appliance. Remove the lower access door. Remove the two screws from attaching switch bracket to the appliance and retain the screws.



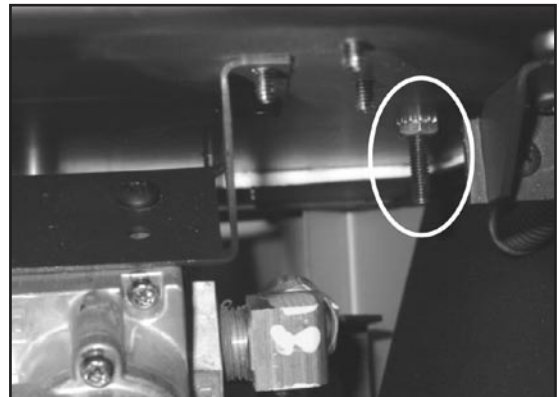
**Figure 8.21** Remove the two screws from the front of the lower heat shield. Loosen the two rear screws. Lower the front of the heat shield.



**Figure 8.22** Attach enclosed wires to the temperature sensor switch/ bracket assembly. The blue wire attaches to the rear of the bracket and one of the black wires from the variable speed control attaches closet to the prepunched screw hole.

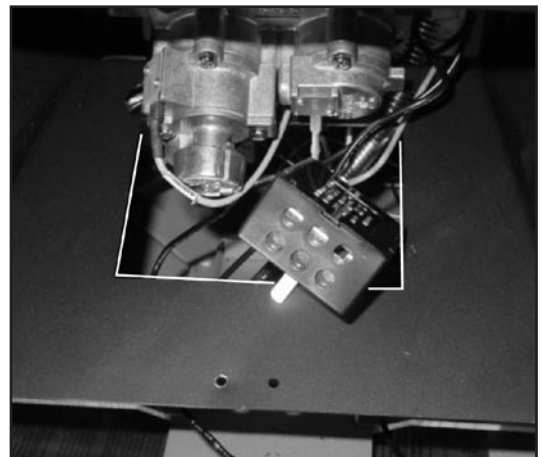


**Figure 8.23** Feed the blue wire and other black wire from the variable speed control behind the gas valve assembly. Insert the wires into the slots indicated.



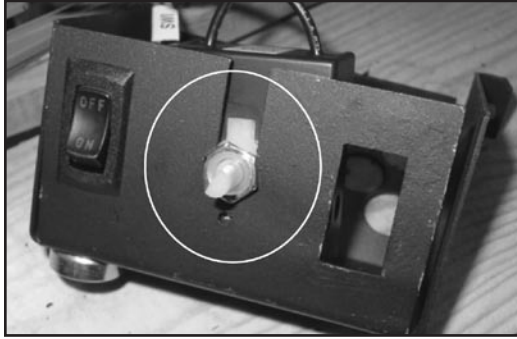
**Figure 8.24** Locate the machine screw underneath the firebox on the right side. Position the temperature sensor switch/ bracket assembly over the machine screw and attach with the wing nut. Finger tighten.

**NOTE: THE SWITCH/BACKET ASSEMBLY MUST BE INSTALLED SO THAT THE SENSOR SWITCH MAKES CONTACT WITH THE BOTTOM OF THE FIREBOX.**

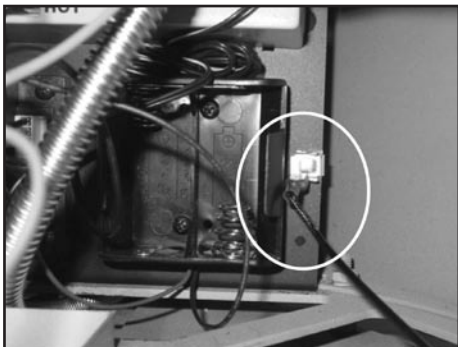


**Figure 8.25** Feed the variable speed control through the front heat shield (opening is highlighted).

Return the front heat shield to its original position. Tighten the rear screws. Replace the front screws previously removed.



**Figure 8.26** Install the variable speed control into the switch bracket with the control nut. Attach the control knob to the stem of the variable speed control.



**Figure 8.27** Attach the ground clip to the control panel. Attach the ground wire extension to the ground clip. Attach the the blower ground wire to the ground wire extension.

Plug the blower cord into the FAN outlet on the junction box. Refer to **Figure 8.29**, on the next page.

Push excess wires neatly towards the rear of the appliance.



**Figure 8.28** Slide the blower into the bracket as indicated. Ensure the blower is pushed back into the bracket to allow the replacement of the lower access door. The magnet strips located on the blower feet are designed to hold the blower in place.

Reattach the switch bracket with the two screws previously removed.

Connect the variable speed control and the temperature sensor switch to the short lead wires of the junction box by plugging in the male and female connectors. See **Figure 8.29**.

Plug appliance in. Turn the 110-120 VAC service "ON" at the circuit breaker and turn the speed control switch to the "ON" position.

## RECOMMENDED OPERATING PROCEDURES

Ignite the fire in the appliance with the variable speed control switch in an "ON" position. The fan will automatically turn on when the temperature sensor switch closes at approximately 110 degrees Fahrenheit. Heated air should be delivered at the outlet grille. The fan will continue to operate after the appliance is turned OFF until the sensor switch opens.

Various conditions (such as appliance model, type of appliance installation, outside air temperature vs. inside air temperature) can contribute to the length of the time the blower remains on after the appliance is turned OFF. The blower can be turned off manually with the speed control switch.

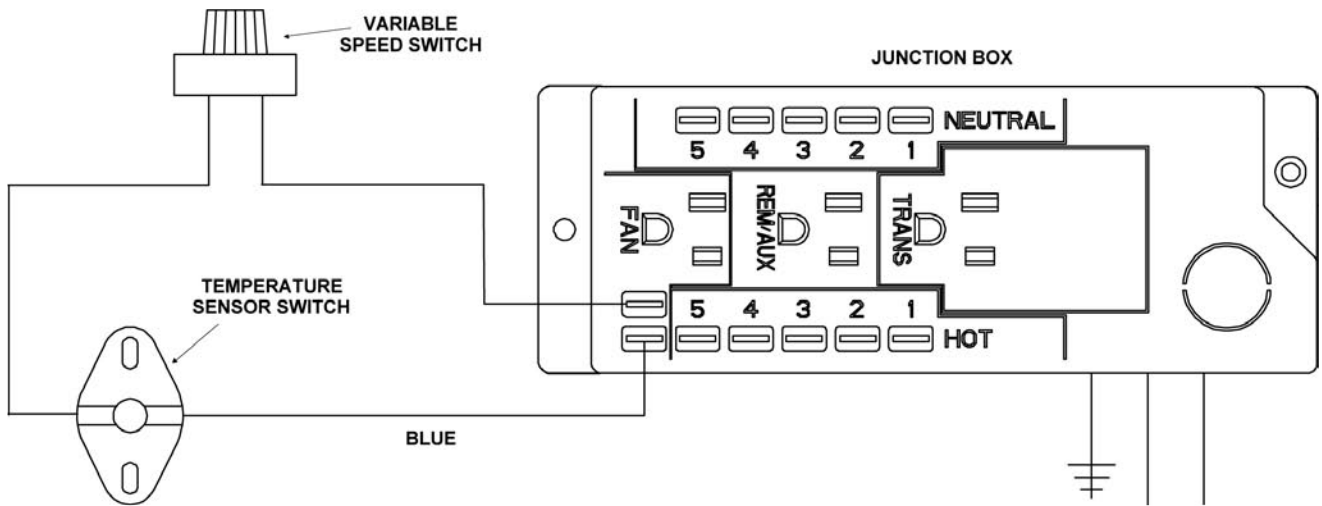


Figure 8.29 Blower Wiring Diagram

**NOTE:** IF ANY OF THE ORIGINAL WIRE AS SUPPLIED WITH THE APPLIANCE MUST BE REPLACED, IT MUST BE REPLACED WITH TYPE 105°C RATED WIRE.

## L. Remote Controls

**TOOLS REQUIRED:** Powered screwdriver with Phillips head bit; hex wrench; 7/16 in. wrench; manometer.

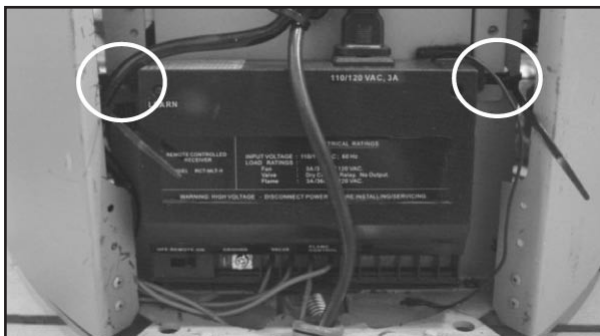
Disconnect electricity at the circuit breaker before beginning this installation.

Familiarize yourself with the instructions enclosed with the remote control kit.

### REMOTE RECEIVER:

Remove the top plate from the appliance. Remove the Allen head screws attaching the back panel to the appliance. Retain screws.

Remove the front glass door assembly and the lower access door.



**Figure 8.30** Using two wire ties from the appliance component bag, mount the remote receiver to the rear of the control panel.

Feed the red and orange wires to the front of the appliance. Remove the optional blower, if installed.

Plug the 3-prong remote receiver cord into the junction box (REM/AUX). Refer to **Figure 8.29**, on page 38.



**Figure 8.31** Plug the 2-prong blower cord directly into the 3-prong polarized plug on the back of the receiver. This receptacle output is 110/120 VAC, 3 AMP.

Attach the ground wire from the blower onto the grounding clip.

Attach red wires from the remote receiver to the ON/OFF switch.

Reinstall the blower into the blower bracket.

**INSTALLING FLAME CONTROL SOLENOID:** (Refer to **Figure 8.33**, on the next page.)

Remove the screw and knob from the variable regulator and discard.

Unscrew the nut from the regulator and discard.

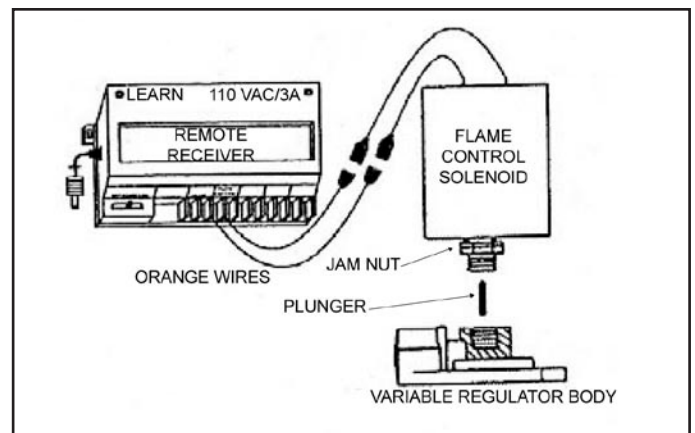
Remove the bag containing a washer and blue and red plungers from the side of the flame control solenoid.

Place washer on flame control solenoid.

Insert the correct plunger (blue - Natural Gas, red - LP) into the flame control solenoid.

Thread the flame control solenoid with the correct plunger into the thread hole in the variable regulator. Turn one to two turns only. **DO NOT** tighten or damage may occur.

### WIRING THE FLAME CONTROL SOLENOID:



**Figure 8.32** Connect the two leads from the flame control solenoid to the orange leads from the receiver.

Install a manometer into the pressure tap.

Plug the remote receiver into the 110-120 VAC power supply.

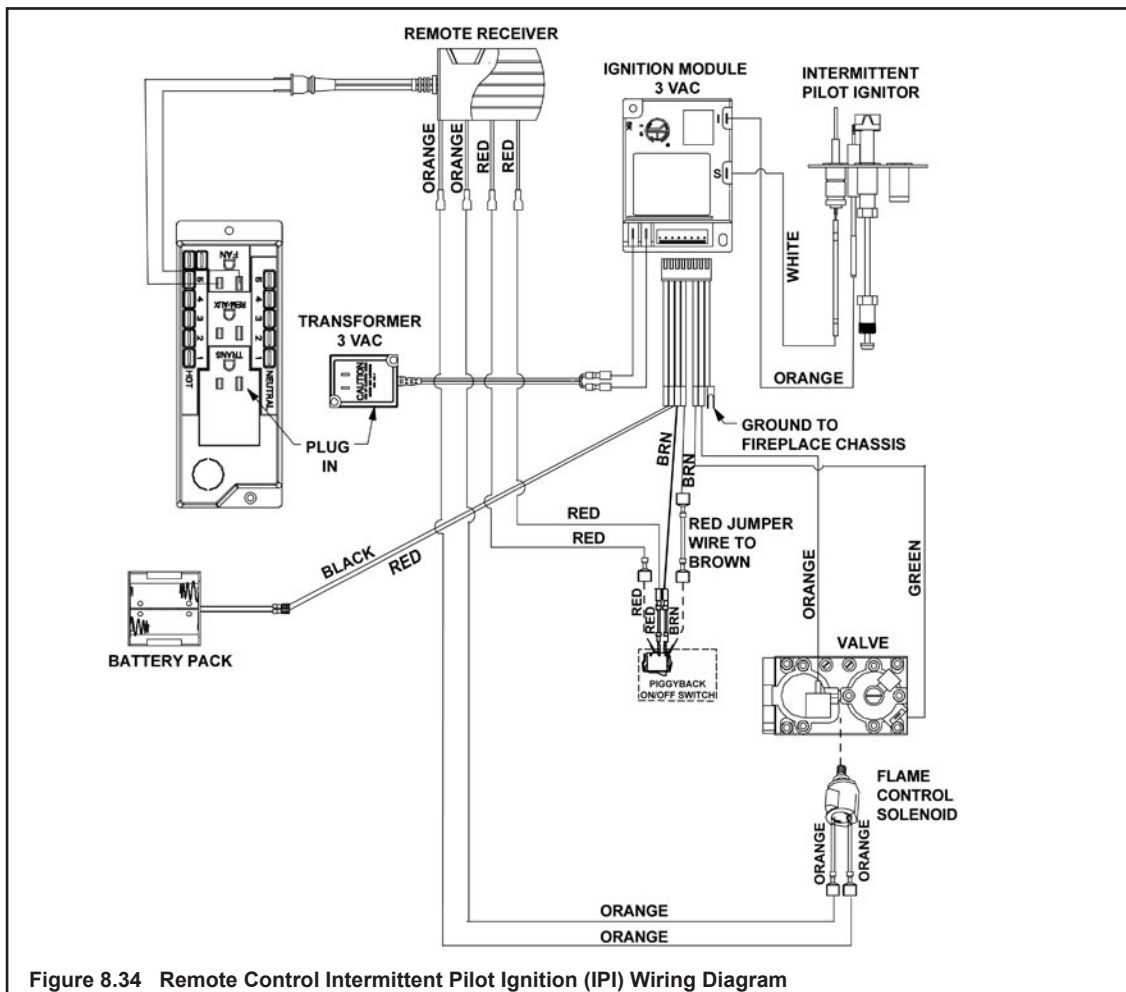
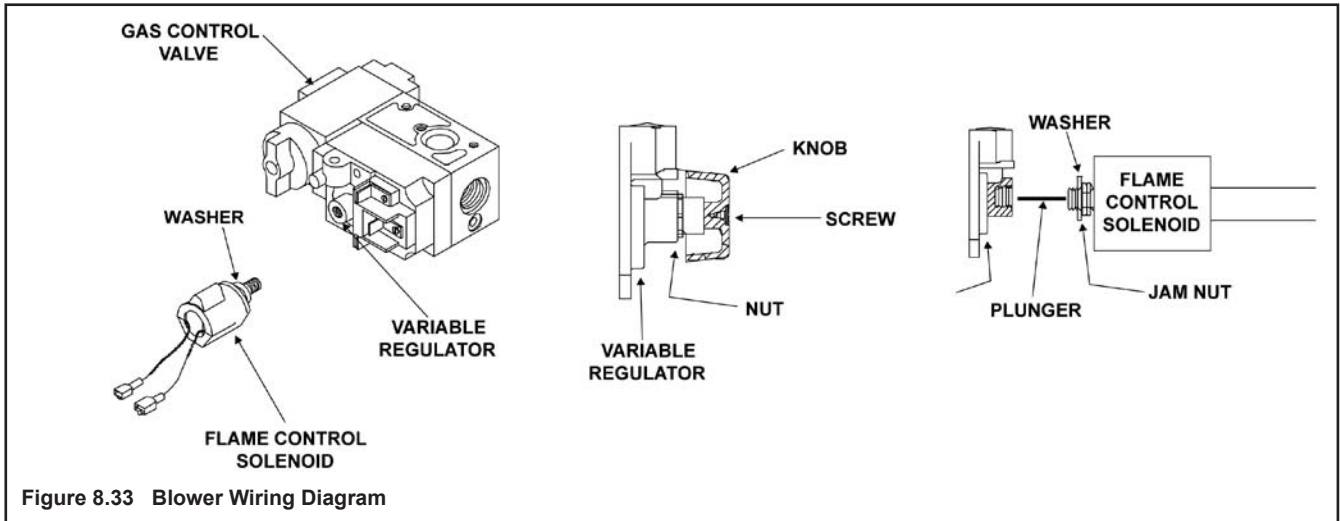
Light the appliance as directed in Section 9 of this manual. Set the manifold pressure on the gas valve by rotating the flame control solenoid. Adjust until the reading on the manometer is 3.5 in. W.C. for natural gas or 10 in. W.C. for LP.

Tighten the jam nut (see **Figure 8.33**, below) to the face of the variable regulator body.

Turn the main gas knob on the gas valve OFF.

Remove the manometer from the pressure tap and screw the tap closed.

Follow the instructions from the remote control kit to operate and program the remote control.



## M. Front Door Glass Assembly Installation

Remove the front door assembly by pulling bottom of front away from appliance and lifting it off of the spring-loaded latches on top of the appliance (see **Figure 8.35**).

**Refer to Figure 8.36:** Position the four flat 1/4 in. (6mm) spacer washers on the front door so that the four mounting screws pass through them. Position the glass over the front door.

Install the four protective barrels into the glass and the four nylon washers on top of the glass.

From inside the door front, pass the screws through to the outside and thread on the caps until tight.

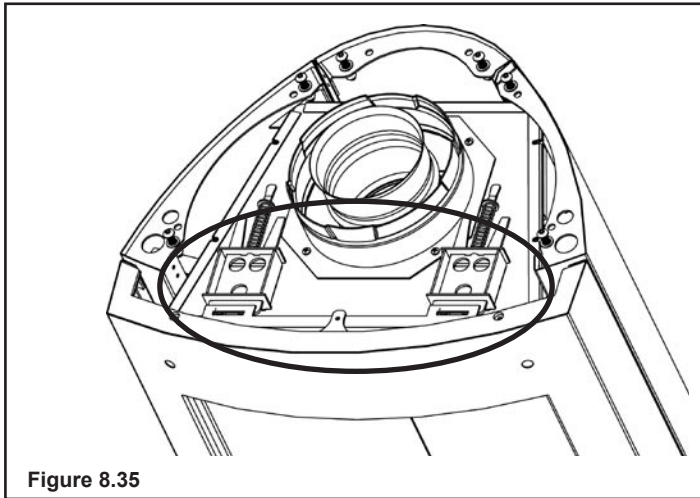


Figure 8.35

## N. Inner Glass Door Assembly Replacement

Turn the appliance OFF and let it cool down before replacing the inner glass door assembly.

With the front door assembly removed from the appliance, remove the inner glass door assembly by disengaging the spring-loaded latches at the bottom of the appliance and lifting off of the two spring-loaded latches at the top of the appliance.

Replace with a new inner glass door assembly.

**NOTE:** The glass, gasketing, and frame must be replaced as a complete unit as supplied by the manufacturer.

**WARNING! Do not use substitute material.**

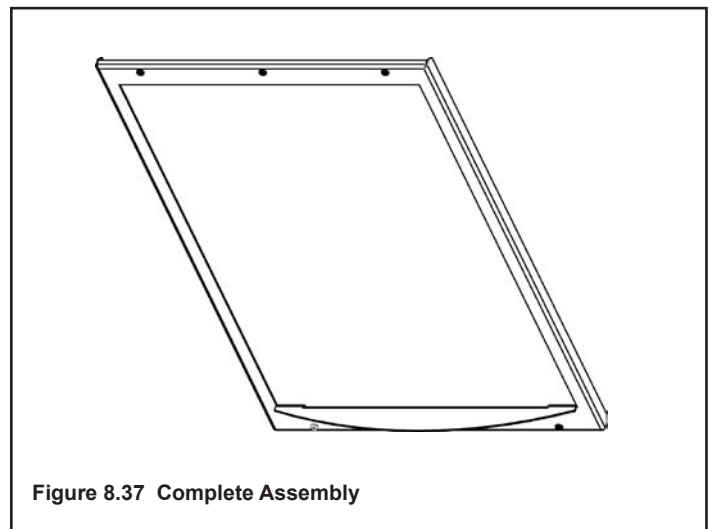


Figure 8.37 Complete Assembly

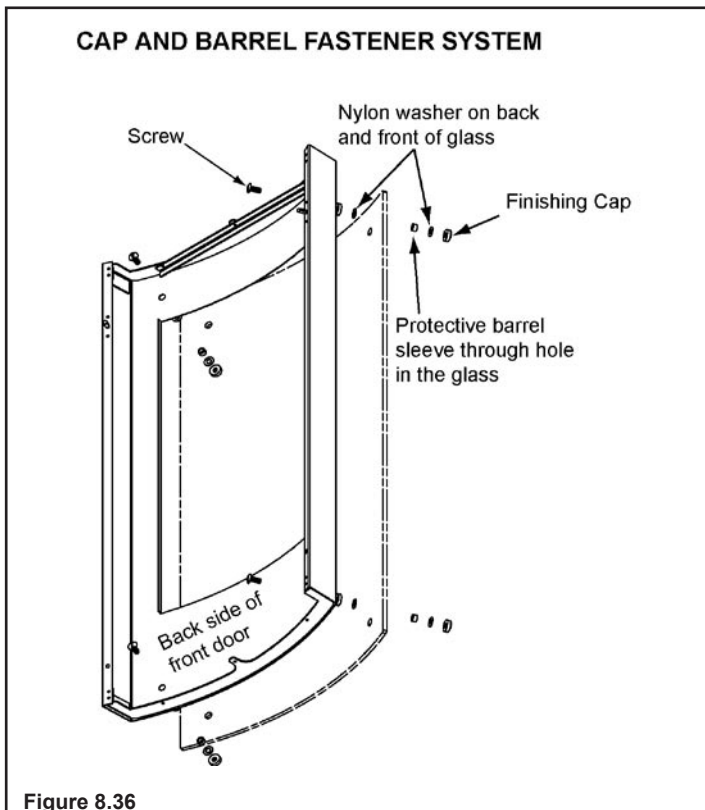


Figure 8.36


# 9


## Operating Instructions

### A. Before Lighting Appliance

Read this entire manual prior to using the appliance. Failure to follow the instructions may result in property damage, bodily injury, or even death.

- Remove all shipping materials from inside and/or underneath the firebox.
- Review proper placement of logs, mineral wool.
- Check the wiring.
- Check the baffle adjustment.
- Ensure that there are no gas leaks.
- Ensure that the glass is sealed and in the proper position.
- Ensure that the flow of combustion and ventilation air is not obstructed (front grilles and vent caps).

**WARNING**




Glass door must be in place when appliance is operating.


Risk of:

- Combustion Fumes
- Fire

Do NOT operate appliance with glass door removed.

- Open viewing glass for servicing only.
- Glass door MUST be in place and sealed before operating appliance.
- Only use glass door certified for use with appliance.
- Glass replacement should be done by qualified technician.


**WARNING**




**HOT! DO NOT TOUCH.**  
**SEVERE BURNS MAY RESULT.**  
**CLOTHING IGNITION MAY RESULT.**

Glass and other surfaces are hot during operation and cool down.

- Keep children away.
- CAREFULLY SUPERVISE children in same room as appliance.
- Alert children and adults to hazards of high temperatures.
- Do NOT operate with protective barriers open or removed.
- Keep clothing, furniture, draperies and other combustibles away.

**WARNING**

Improper installation, adjustment, alteration, service or maintenance can cause injury or property damage. Refer to the owner's information manual provided with this appliance. For assistance or additional information consult a qualified installer, service agency or the gas supplier.

**WARNING**

Do NOT use this appliance if any part has been under water. Immediately call a qualified service technician to inspect the appliance and to replace any part of the control system and any gas control which has been under water.

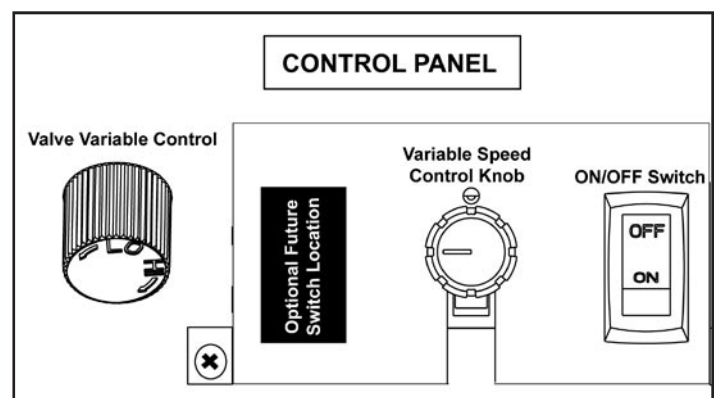
### B. Controls

**ON/OFF SWITCH:** When this switch is in the ON position, the pilot ignitor is engaged until temperature is established. The burner automatically turns on.

**VALVE VARIABLE CONTROL:** This knob controls the flame height from low ("LO") to high ("HI"). The indicator on the valve indicates the position of the knob.

**VARIABLE SPEED CONTROL:** The blower is optional installed on the appliance and this knob controls the speed of the blower that pushes the heated air into the room.

**NOTE:** If using a remote control wall switch, or thermostat, the On/Off Switch must be left "OFF". Turning the On/Off Switch to "ON" will keep the appliance on continually.



## C. Lighting Appliance

### IntelliFire® Ignition System

#### FOR YOUR SAFETY READ BEFORE LIGHTING

**WARNING:** If you do not follow these instructions exactly, a fire or explosion may result causing property damage, personal injury or loss of life.

- A.** This appliance is equipped with an intermittent pilot ignition (IPI) device which automatically lights the burner. Do not try to light the burner by hand.
- B. BEFORE LIGHTING,** smell all around the appliance area for gas. Be sure to smell next to the floor because some gas is heavier than air and will settle on the floor.
- WHAT TO DO IF YOU SMELL GAS**
- Do not try to light any appliance.
  - Do not touch any electric switch; do not use any phone in your building.
  - Immediately call your gas supplier from a neighbor's phone. Follow the gas supplier's instructions.
  - If you cannot reach your gas supplier, call the fire department.
- C.** Do not use this appliance if any part has been under water. Immediately call a qualified service technician to inspect the appliance and to replace any part of the control system and any gas control which has been under water.

#### WARNING:

##### DO NOT CONNECT 110 VAC TO THE CONTROL VALVE.

Improper installation, adjustment, alteration, service or maintenance can cause injury or property damage. Refer to the owner's information manual provided with this appliance.

This appliance needs fresh air for safe operation and must be installed so there are provisions for adequate combustion and ventilation air.

If not installed, operated, and maintained in accordance with the manufacturer's instructions, this product could expose you to substances in fuel or fuel combustion which are known to the State of California to cause cancer, birth defects, or other reproductive harm. Keep burner and control compartment clean. See installation and operating instructions accompanying appliance.

For additional information on operating your Hearth Technologies appliance, please refer to [www.Fireplaces.com](http://www.Fireplaces.com).

#### Final Inspection by

#### CAUTION:

Hot while in operation. Do not touch. Keep children, clothing, furniture, gasoline and other liquids having flammable vapors away.

Do not operate the appliance with panel(s) removed, cracked or broken. Replacement of the panel(s) should be done by a licensed or qualified service person.

#### NOT FOR USE WITH SOLID FUEL

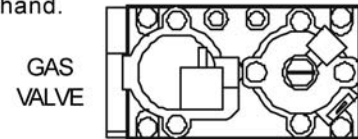
For use with natural gas and propane. A conversion kit, as supplied by the manufacturer, shall be used to convert this appliance to the alternate fuel.

#### Also Certified for Installation in a Bedroom or a Bedsitting Room.

For assistance or additional information, consult a qualified installer, service agency or the gas supplier.

#### LIGHTING INSTRUCTIONS (IPI)

1. Turn off all electric power to the appliance.
2. This appliance is equipped with an ignition device which automatically lights the burner. Do not try to light the burner by hand.



3. Wait five (5) minutes to clear out any gas. Then smell for gas, including near the floor. If you smell gas, STOP! Follow "B" in the Safety Information located on the left side of this label. If you don't smell gas, go to next step.
4. Turn on all electric power to the appliance.
5. To light the burner, flip the ON/OFF switch to the "ON" position. (The ON/OFF switch may include a wall switch if so equipped).
6. If the appliance will not operate, follow the instructions "To Turn Off Gas to Appliance" and call your service technician or gas supplier.

#### TO TURN OFF GAS TO APPLIANCE

1. Turn off all electric power to the appliance if service is to be performed.
2. Flip ON/OFF switch to the "OFF" position.

593-913C



## D. After Appliance is Lit

### Initial Break-in Procedure

When you light your appliance, you may notice that it produces heat which does have an associated odor or smell. If you feel this odor is excessive it may require the initial three to four hour continuous burn on high followed by a second burn up to 12 hours to fully drive off any odor from paint and lubricants used in the manufacturing process. Condensation on the inside of the glass is normal.



**NOTE:** The appliance should be run three to four hours on the initial start-up. Turn it off and let it cool completely. Remove and clean the glass. Replace the glass and run the appliance for an additional 12 hours. This will help to cure the products used in the paint and logs.

During this break-in period it is recommended that some windows in the house be opened for air circulation. This will help avoid setting off smoke detectors, and help eliminate any odors associated with the appliance's initial burning.

	 <b>WARNING</b>
	<p>Fire Risk. High Temperatures.</p> <p>Keep combustible household items away from appliance. Do NOT obstruct combustion and ventilation air.</p> <ul style="list-style-type: none"> <li>• Do NOT place combustible items on top of or in front of appliance.</li> <li>• Keep furniture, draperies away from appliance.</li> </ul>

<b>CAUTION</b>
<ul style="list-style-type: none"> <li>• Prevent accidental appliance operation when not attended.</li> <li>• Unplug or remove batteries from remote control if absent or if appliance will not be used for an extended period of time.</li> <li>• Property damage possible from elevated temperatures.</li> </ul>

<b>CAUTION</b>
<p>Smoke and odors released during initial operation.</p> <ul style="list-style-type: none"> <li>• Open windows for air circulation.</li> <li>• Leave room during initial operation.</li> <li>• Smoke may set off smoke detectors.</li> </ul> <p>Smoke and odors may be irritating to sensitive individuals.</p>

	 <b>WARNING</b>
	<p>Fire Hazard. Keep combustible materials, gasoline and other flammable vapors and liquids clear of appliance.</p> <ul style="list-style-type: none"> <li>• Do NOT store flammable materials in the appliance's vicinity.</li> <li>• Do NOT use gasoline, lantern fuel, kerosene, charcoal lighter fluid or similar liquids in this appliance.</li> <li>• Combustible materials may ignite.</li> </ul>

## E. Frequently Asked Questions

ISSUE	SOLUTIONS
Condensation on the glass	This is a result of gas combustion and temperature variations. As the appliance warms, this condensation will disappear.
Blue flames	This is a result of normal operation and the flames will begin to yellow as the appliance is allowed to burn for 20 to 40 minutes.
Odor from appliance	When first operated, this appliance may release an odor for the first several hours. This is caused by the curing of the paint and the burning off of any oils remaining from manufacturing.
Film on the glass	This is a normal result of the curing process of the paint and logs. Glass should be cleaned within 3 to 4 hours of initial burning to remove deposits left by oils from the manufacturing process. A non-abrasive cleaner such as gas appliance cleaner may be necessary. See your dealer.
Metallic noise	Noise is caused by metal expanding and contracting as it heats up and cools down, similar to the sound produced by a furnace or heating duct. This noise does not affect the operation or longevity of the appliance.
Is it normal to see the pilot flame burn continually?	In an IntelliFire® ignition system it is normal to see the pilot flame, but it should turn off when ON/OFF is turned off.

# 10

## Troubleshooting

With proper installation, operation, and maintenance your gas appliance will provide years of trouble-free service. If you do experience a problem, this troubleshooting guide will assist a qualified service person in the diagnosis of a problem and the corrective action to be taken. This troubleshooting guide can only be used by a qualified service technician.

Symptom	Possible Causes	Corrective Actions
1. The ignitor/module makes noise, but no spark.	a. Incorrect wiring.	Verify "S" wire (white) for sensor and "I" wire (orange) for ignitor are connected to correct terminals on module and pilot assembly. Reversed wires at the module may cause system to make sparking noise, but spark may not be present at pilot hood.
	b. Loose connections or electrical shorts in the wiring.	Verify no loose connections or electrical shorts in wiring from module to pilot assembly. Rod closest to pilot hood should be ignitor. Verify connections underneath pilot assembly are tight; also, verify connections are not grounding out to metal chassis, pilot burner, pilot enclosure, mesh screen if present, or any other metal object.
	c. Ignitor gap is too large.	Verify gap of ignitor to pilot hood. The gap should be approximately .17 inch or 1/8 in. (3mm).
	d. Faulty module.	Turn ON/OFF rocker switch or wall switch to OFF position. Remove ignitor wire "I" from module. Place ON/OFF rocker switch or wall switch in ON position. Hold ground wire about 3/16 in. (5mm) away from "I" terminal on module. If there is no spark at "I" terminal, module must be replaced. If there is a spark at "I" terminal, module is fine. Inspect pilot assembly for shorted sparker wire or cracked insulator around electrode.
2. Pilot won't light, there is no noise or spark.	a. Transformer installed correctly.	Verify that transformer is installed and plugged into module. Check voltage of transformer under load at spade connection on module with ON/OFF switch in ON position. Acceptable reading of a good transformer are between 3.2 and 2.8 volts AC.
	b. A shorted or loose connection in wiring configuration or wiring harness.	Remove and reinstall the wiring harness that plugs into module. Verify there is a tight fit. Verify pilot assembly wiring to module. Remove and verify continuity of each wire in wiring harness..
	c. Improper wall switch wiring.	Verify that 110/VAC power is "ON" to junction box.
	d. Module not grounded.	Verify black ground wire from module wire harness is grounded to metal chassis of appliance.
	e. Faulty module.	Turn ON/OFF rocker switch or wall switch to OFF position. Remove ignitor wire "I" from module. Place ON/OFF rocker switch or wall switch in ON position. Hold ground wire about 3/16 in. (5mm) away from "I" terminal on module. If there is no spark at "I" terminal, module must be replaced. If there is a spark at terminal "I", module if fine. Inspect pilot assembly for shorted sparker wire or cracked insulator around electrode.

Symptom	Possible Causes	Corrective Actions
3. Pilot lights but continues to spark, and main burner will not ignite. (If the pilot continues to spark after the pilot flame has been lit, flame rectification has not occurred.)	a. A shorted or loose connection in sensor rod.	Verify all connections to wiring diagram in manual. Verify connections underneath pilot assembly are tight. Verify connections are not grounding out to metal chassis, pilot burner, pilot enclosure or screen if present, or any other metal objects.
	b. Poor flame rectification or contaminated sensor rod.	Verify that flame is engulfing sensor rod. If the pilot assembly does not have a ground strap, consider installing one to increase flame rectification. Verify correct pilot orifice is installed and inlet gas specifications. Flame carries rectification current, not the gas. If flame lifts from pilot hood, the circuit is broken. A wrong orifice or too high an inlet pressure can cause pilot flame to lift. The sensor rod may be contaminated. Clean sensor rod with emery cloth.
	c. Module is not grounded.	Verify that module is securely grounded to metal chassis of appliance. Verify that wire harness is firmly connected to module.
	d. Damaged pilot assembly or dirty sensor rod	Verify that ceramic insulator around the sensor rod is not cracked, damaged, or loose. Verify connection from sensor rod to white sensor wire. Clean sensor rod with emery cloth to remove any contaminants that may have accumulated on the sensor rod. Verify continuity with a multimeter with ohms set at lowest range.
	e. Faulty module.	Turn ON/OFF rocker switch or wall switch to OFF position. Remove ignitor wire "I" from module. Place ON/OFF rocker switch or wall switch in ON position. Hold ground wire about 3/16 in. (5mm) away from "I" terminal on module. If there is no spark at "I" terminal, module must be replaced. If there is a spark at "I" terminal, module is fine. Inspect pilot assembly for shorted spark wire or cracked insulator around electrode.
4. Pilot sparks, but pilot will not light.	a. Correct gas supply.	Verify that incoming gas line ball valve is "open". Verify that inlet pressure reading is within acceptable limits, inlet pressure must not exceed 14 in. (356mm) W.C
	b. Ignitor gap is too large.	Verify that spark gap from ignitor to pilot hood is .17 in. or 1/8 in.
	c. Module is not grounded.	Verify module is securely grounded to metal chassis of appliance.
	d. Module voltage output / Valve/Pilot solenoid ohms readings.	Verify battery voltage is at least 2.7 volts. Replace batteries if voltage is below 2.7.

# 11

## Maintaining and Servicing Appliance

Although the frequency of your appliance servicing and maintenance will depend on use and the type of installation, a qualified service technician should perform an appliance check-up at the beginning of each heating season.

### WARNING

Risk of injury or property damage.

#### Before servicing:

- Turn off gas.
- Turn off electricity to appliance.
- Ensure appliance is completely cooled.

#### After servicing:

- Replace any screen or barrier that was removed.
- Reseal and reinstall any venting removed for servicing.

### WARNING

Annual inspection by qualified technician recommended.

#### Check:

- Condition of glass, glass assembly and glass seal.
- Obstructions of combustion and ventilation air.
- Obstructions of termination cap.
- Burner ignition and operation.
- Burner air shutter adjustment
- Gas connections and fittings.

#### Clean:

- Glass
- Air passageways, grilles, control compartment
- Burner, burner ports

#### Risk of:

- Fire
- Delayed ignition or explosion
- Exposure to combustion fumes
- Odors



### CAUTION

Handle glass assembly with care.

**NOTE:** Clean glass after initial 3-4 hours operation. **Longer operation without cleaning glass may cause a permanent white film on glass.**

#### When cleaning glass door:

- Avoid striking, scratching or slamming glass.
  - Do NOT use abrasive cleaners.
  - Use a hard water deposit glass cleaner on white film.
  - Do NOT clean glass when hot.
  - Turn off appliance after 3-4 hours of operation and ALLOW TO COOL.
  - Remove and clean glass assembly.
  - Replace glass assembly and operate appliance for additional 12 hours.
- Refer to maintenance instructions.

### WARNING



Inspect external vent cap regularly.

- Ensure no debris blocks cap.
- Combustible materials blocking cap may ignite.
- Restricted air flow affects burner operation.

## A. Maintenance Tasks

Inspect	Maintenance Tasks
Doors	1. Inspect for scratches, dents or other damage and repair as necessary.
	2. Verify no obstructions to air flow.
	3. Verify maintenance of proper clearance to combustible household objects.
Gasket Seal, Glass Assembly and Glass	1. Inspect gasket seal and its condition.
	2. Inspect glass for scratches and nicks that can lead to breakage when exposed to heat.
	3. Confirm there is no damage to glass or glass frame, Replace as necessary.
	4. Verify that latches engage properly and glass attachment components are intact and operating properly. Replace as necessary.
	5. Clean glass. Replace glass assembly if severely coated with silicate deposits that cannot be removed.
Valve Compartment and Firebox Top	1. Vacuum and wipe out dust, cobwebs, debris or pet hair. Use caution when cleaning these areas. Screw tips that have penetrated the sheet metal are sharp and should be avoided.
	2. Remove any foreign objects.
	3. Verify unobstructed air circulation.
Logs	1. Inspect for broken, damaged, or missing logs. Replace as necessary.
	2. Verify correct log placement and no flame impingement causing sooting. Correct as necessary.
Firebox	1. Inspect for paint condition, warpage, corrosion or perforation. Sand and repaint as necessary.
	2. Replace appliance if firebox has been perforated.
Burner Ignition and Operation	1. Verify burner is properly secured and aligned with pilot or igniter.
	2. Clean off burner top, inspect for plugged ports, corrosion or deterioration. Replace burner if necessary.
	3. Replace ember material with new dime-size and shape peices. Do not block ports or obstruct lighting paths.
	4. Check for smooth lighting and ignition carryover to all ports. Verify there is no ignition delay.
	5. Inspect for lifting and other flame problems.
	6. Inspect orifice for soot, dirt or corrosion.
	7. Verify manifold and inlet pressures. Adjust regulator as required.
	8. Inspect pilot flame strength. Clean or replace orifice as necessary.
	9. Inspect thermocouple/thermopile sensor rod for soot, corrosion and deterioration. Clean with emery cloth or replace as required.
	10. Verify millivolt output. Replace as necessary.
Venting	1. Inspect venting for blockage or obstruction such as bird nests, leaves, etc.
	2. Confirm that termination cap remains clear and unobstructed by plants, etc.
	3. Verify that termination cap clearance to subsequent construction (building additions, decks, fences or sheds) has been maintained.
	4. Inspect for corrosion or separation.
	5. Verify weather stripping, sealing and flashing remains intact.
Remote Controls	1. Verify operation of remote.
	2. Replace batteries in remote transmitters and battery-powered receivers.



# 12

## Reference Materials

### A. Appliance Dimension Diagram

Dimensions are actual appliance dimensions. Use for reference only. For clearances to combustibles refer to Section 3.

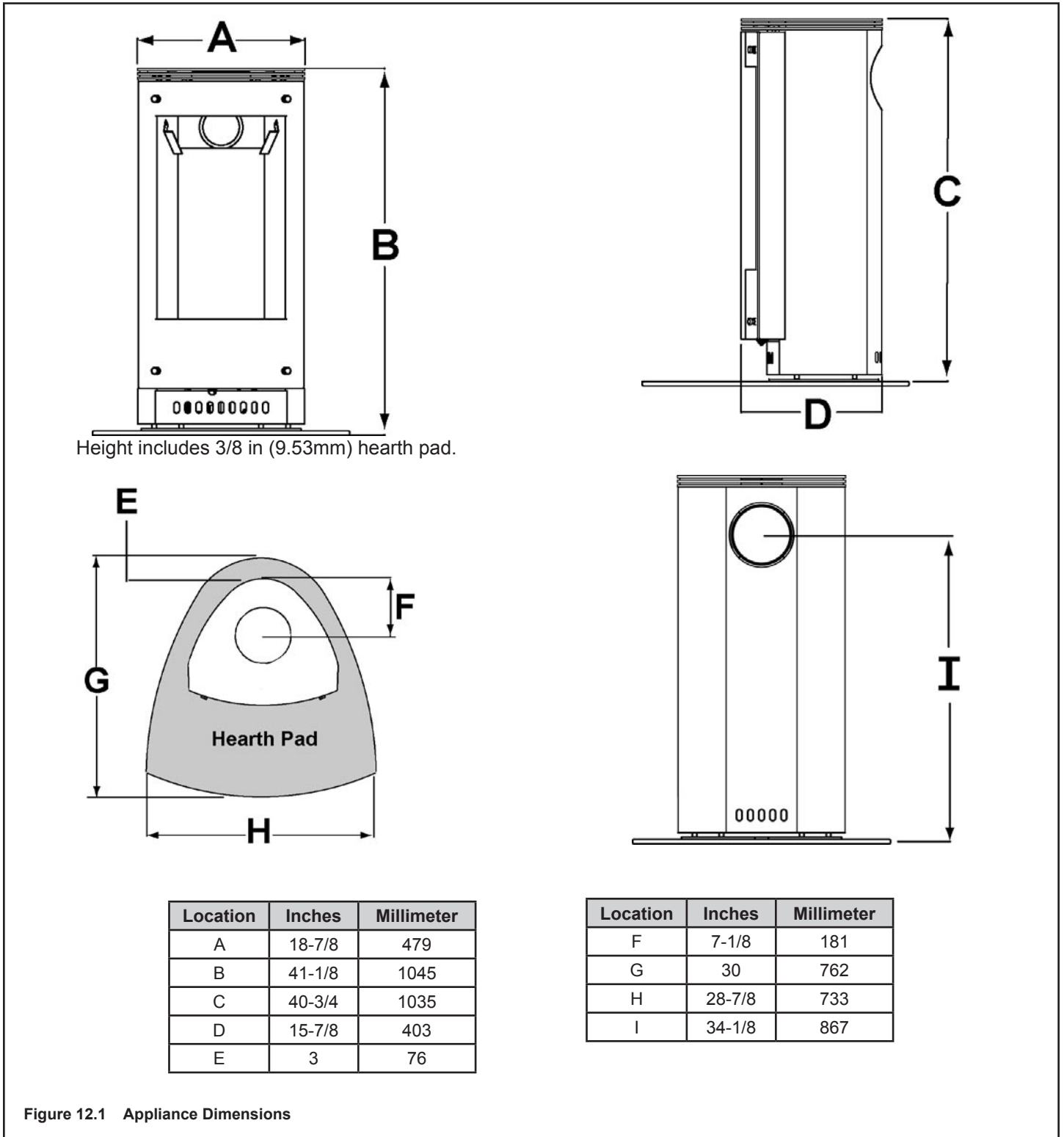
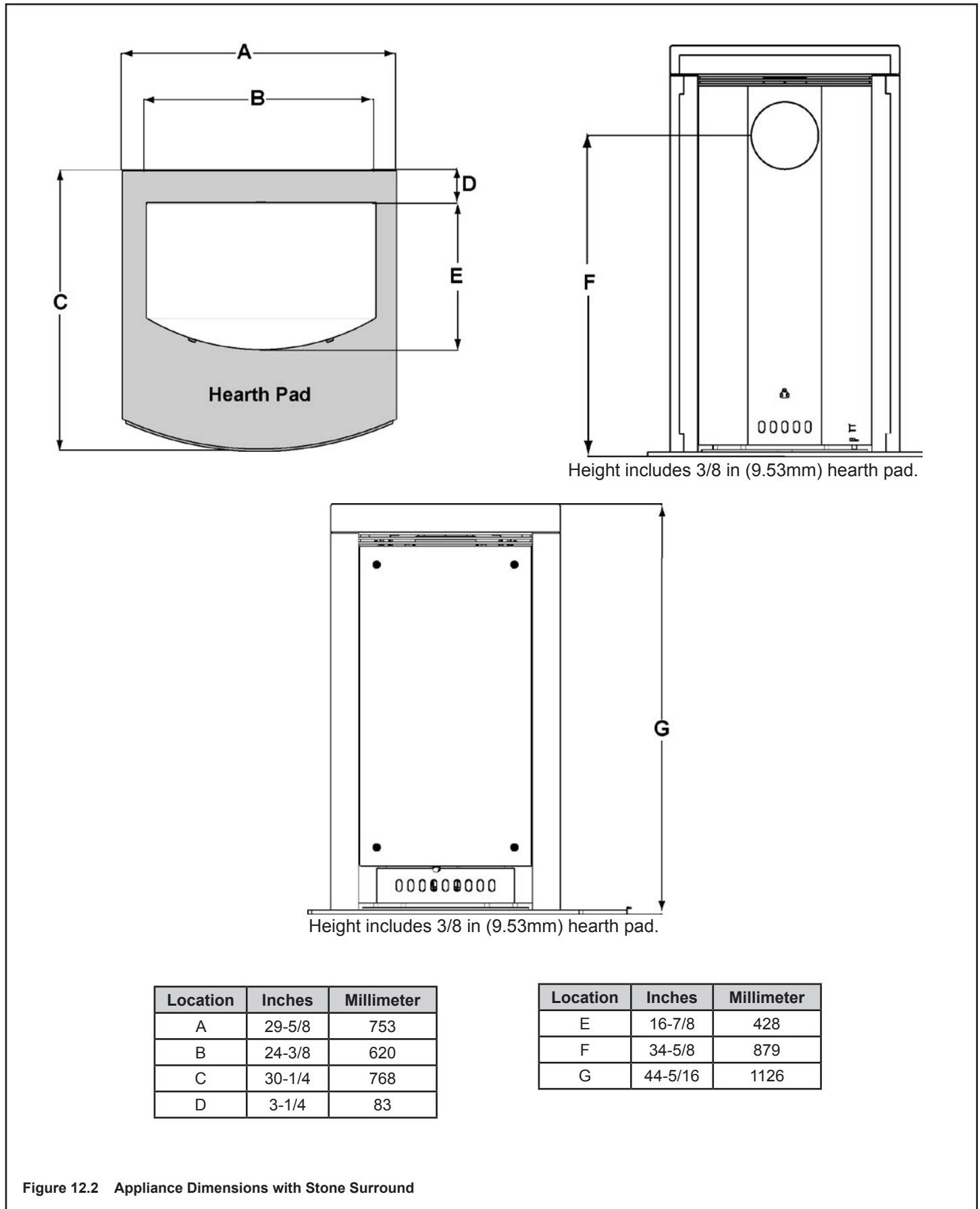
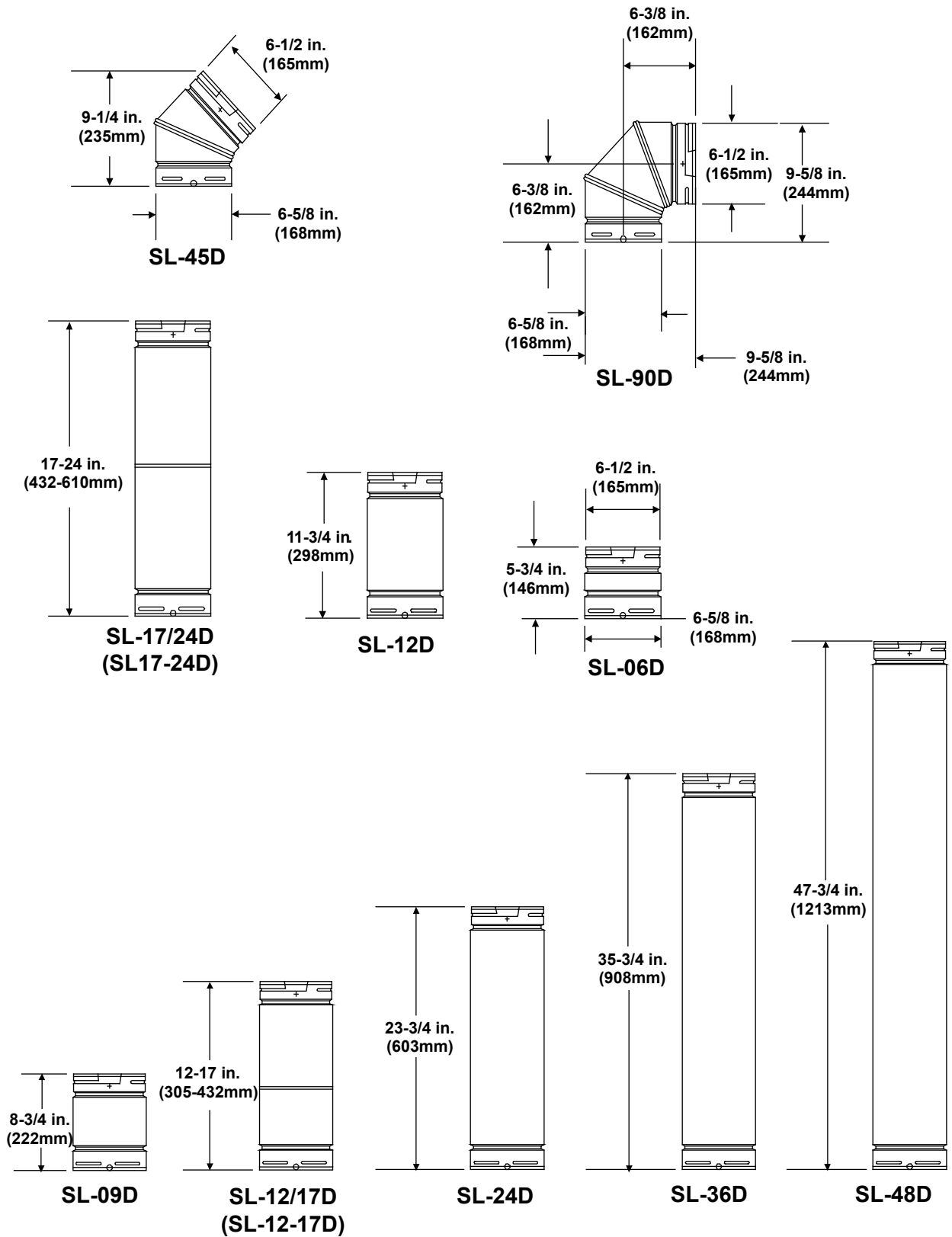


Figure 12.1 Appliance Dimensions

## B. Appliance Dimension with Stone Surround Diagram



### C. Vent Components Diagram



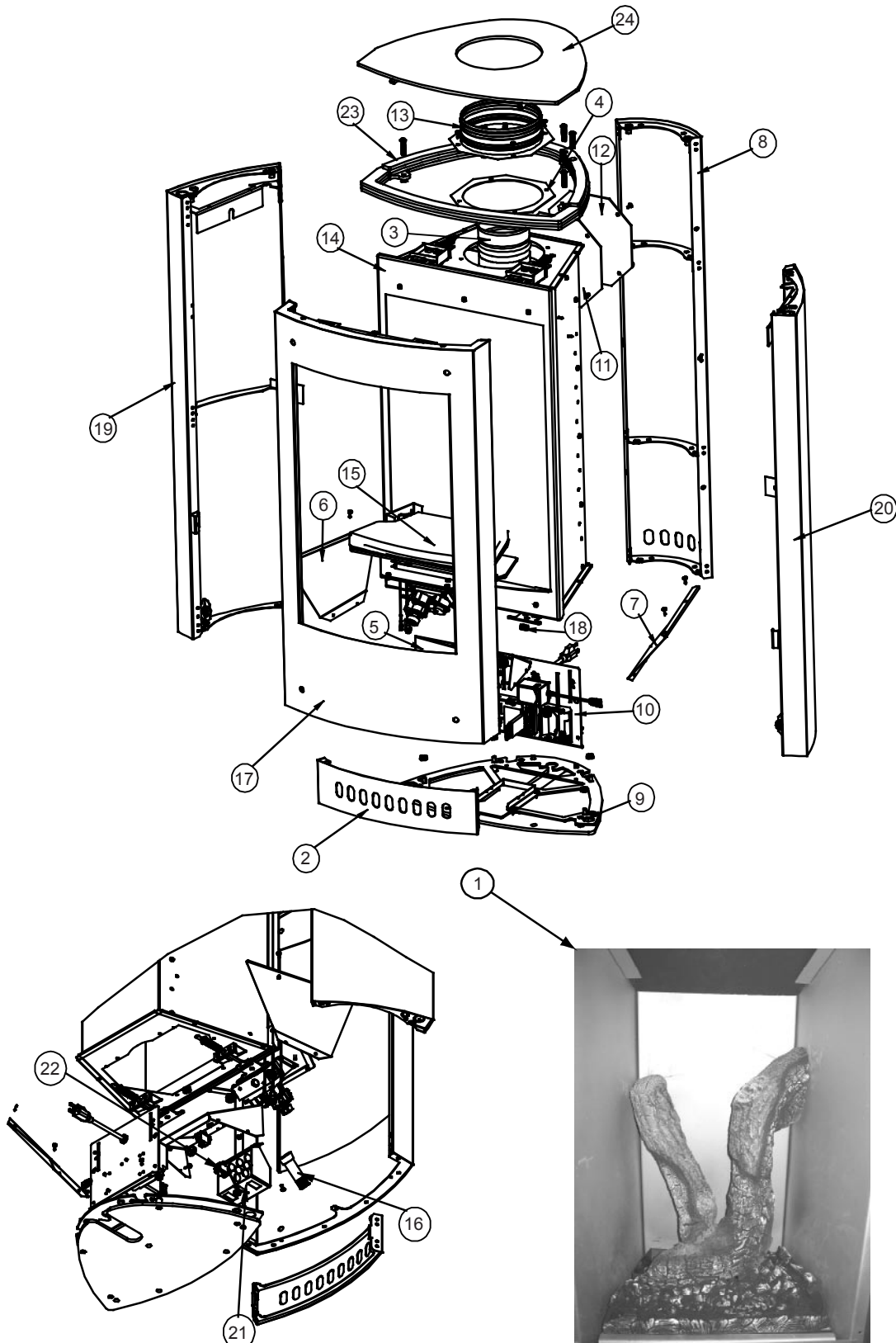
SL D-Series Direct Vent Component Specifications (4 in. (102 mm) inner pipe 6-5/8 in. (168 mm) outer pipe)

Figure 12.3 SL-D Series Vent Components

## D. Vent Components List

COMPONENTS	
930D	Ceiling Support / Wall Thimble, Black
941	Cathedral Ceiling Support, Black
908B	6 inch Pipe Length, Black
907B	9 inch Pipe Length, Black
906B	12 inch Pipe Length, Black
904B	24 inch Pipe Length, Black
903B	36 inch Pipe Length, Black
902B	48 inch Pipe Length, Black
911B	11 inch - 14-5/8 inch Pipe Length, Black
912B	12 inch - 17 inch Pipe, Adjustable, Black
945B	45 degree Elbow, Black
990B	90 degree Elbow, Black
SL-06D	6 inch Pipe
SL-09D	9 inch Pipe
SL-12D	12 inch Pipe
SL-24D	24 inch Pipe
SL-36D	36 inch Pipe
SL-48D	48 inch Pipe
SL-45D	45 degree Elbow
SL-90D	90 degree Elbow
SL-F6D	0/12 - 6/12 Roof Flashing
SL-F12D	7/12 - 12/12 Roof Flashing
SL-SCD	Storm Collar
SL-FCD	Ceiling Firestop
SL-FWD	Wall Firestop
SLK-RHC	Radiant Heat Shield
SL-PSD	Pipe Support Hanger
950	Vinyl Protector Kit - SL Pipe
DRC-RADIUS	Decorative Radius Cover
HTI-DV-WT	Wall Thimble
844-9550	Slim Line Wall Thimble

TERMINATION KITS	
SLK-01TRD	Trapezoid Termination Kit 7-3/4 inch - 11 inch, 2 Firestops
SLK-991DA	Vertical Termination Cap - High Wind
970D	Horizontal Termination Kit (includes 904B, 930d, SLK-01TRD)
SLK-SNKD	Snorkel Kit
LINK-STOVE	Adapter Kit (includes 30 ft. of 4 inch flex, adapters, wall thimble, masonry & ZC flashing, 991DA cap and hardware package)
VPK-DV	Vinyl Siding Protector Kit
841-0670	HHW2 Horizontal High Wind Cap (recommended for optimal performance)
844-4491	HHW2K Horizontal Kit (one 90 degree black wall thimble, 24 inch black pipe, 11 inch - 14-5/8 inch adjustable vent, HHW2 termination cap)
844-8921	RHVK Snorkel Kit (with Dura-Vent parts 911B and 940)
MISCELLANEOUS	
953	Storm Collar
963	Ceiling Firestop
988	Wall Strap
9456	Attic Insulation Shield
923GK	Chimney Liner Termination Kit
923GCL	Co-axial / Co-lineal Appliance Connector
909B	Retrofit Adj. Chimney Connector Retrofit Chimney Connector Plate

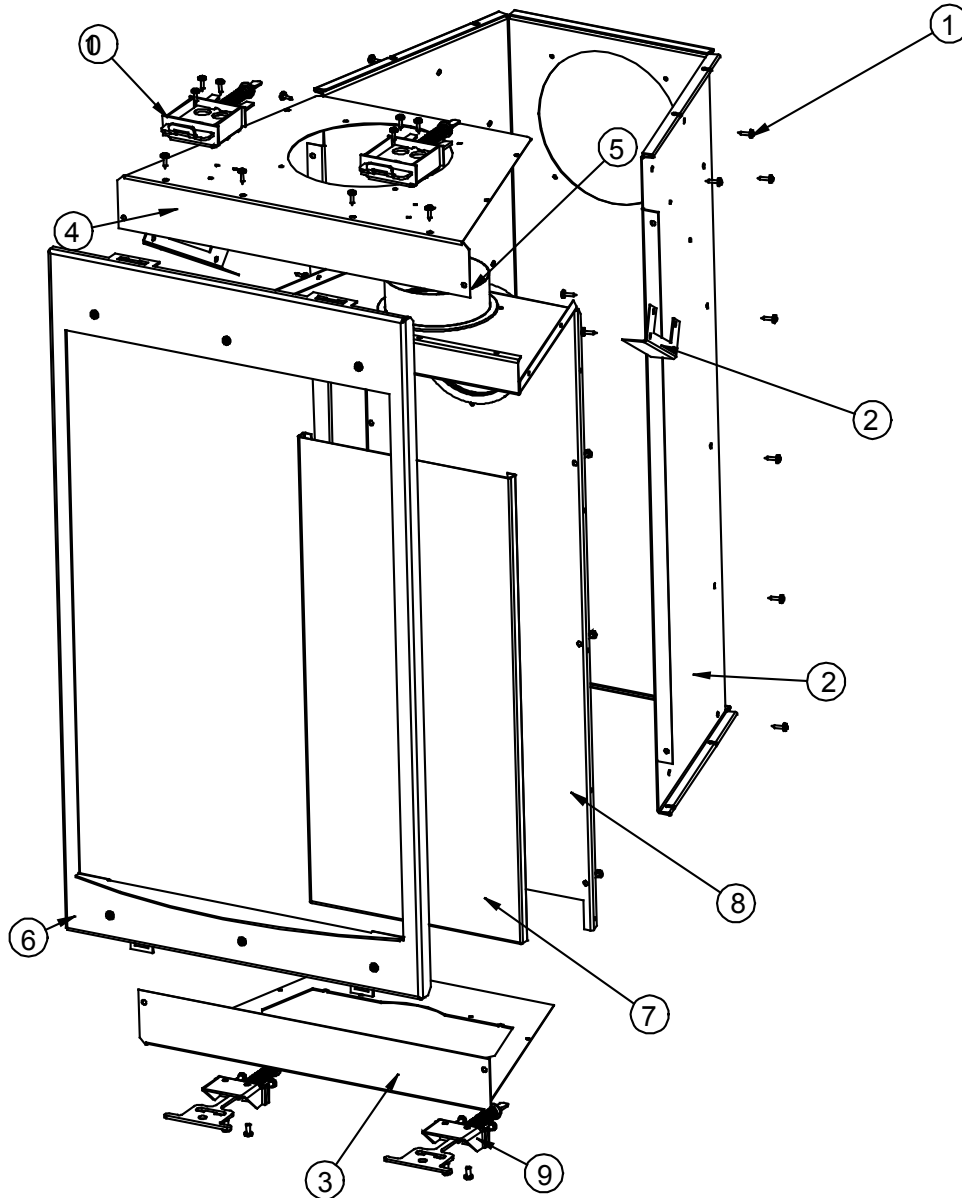


\* Part number list on following page.

**IMPORTANT:** THIS IS DATED INFORMATION. The most current information is located on your dealer's VIP site. When ordering, supply serial and model numbers to ensure correct service parts.

ITEM	DESCRIPTION	SERIAL #	PART #
1	2-piece Log Set		7031-033
2	Access Door Assembly		7031-023
3	Adapter, 4 inch flue collar		200-2470
4	Adapter Gasket		460-0610
5	Air Deflector Glass		7031-140
6	Air Deflector, Left		7031-159
7	Air Deflector, Right		7031-158
8	Back Panel Assembly		7031-021
	Baffle		7031-219
9	Bottom Plate Assembly		7031-025
10	Control Assembly		7031-027
11	Cover Plate		7010-159
12	Cover Plate Gasket		7010-160
13	DV Adapter		7000-162
14	Firebox Assembly		7031-002
15	Firebox Bottom Assembly		7031-012
16	Flame Control Knob		571-531
	Flue Collar		7018-117
	Flue Restrictor Plate		7031-222
17	Front Door Assembly		7031-019
18	Grommet		229-0170
	LP Orifice		450-2650
	NG Orifice		450-2630
	Pilot Assembly, NG		2090-012
	Pilot Shield		7031-234
19	Side Assembly, Left		7031-024
20	Side Assembly, Right		7031-020
	Snap Disc, Ceramic		107-531
21	Switch Bracket		7031-177
22	Switch, Rocker, ON/OFF		230-0730
23	Top Assembly		7031-013
24	Top Vent Assembly, Removable		7031-017
	Valve, Gas, LP		750-501
	Valve, Gas, NG		750-500
	Variable Speed Control		100-510A

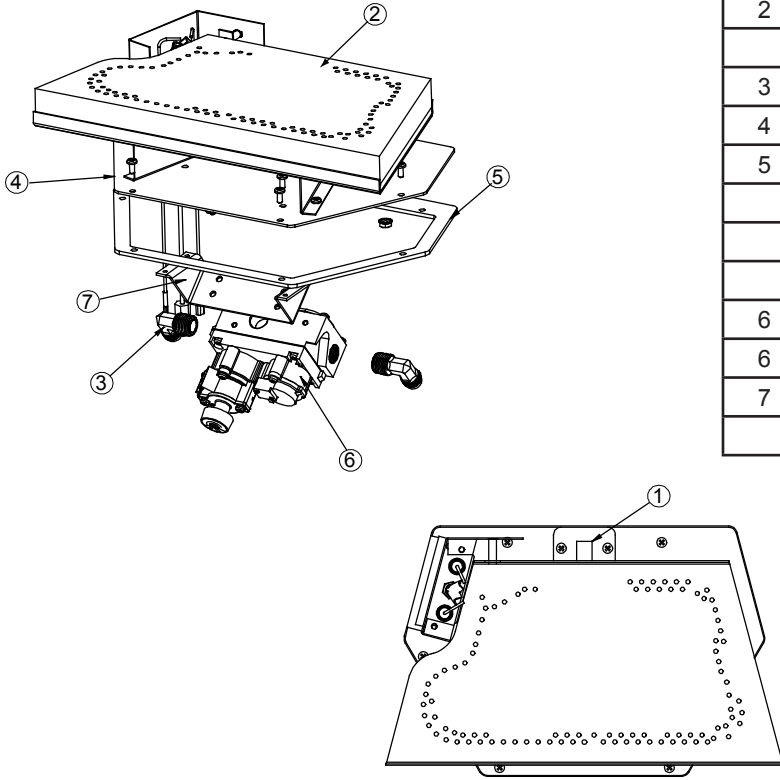
### Firebox Assembly



ITEM	DESCRIPTION	SERIAL #	PART #
1	Baffle Support		7031-137
2	Firebox Back and Sides		N/A
3	Firebox Bottom		N/A
4	Firebox Top		N/A
5	Flue Collar		N/A

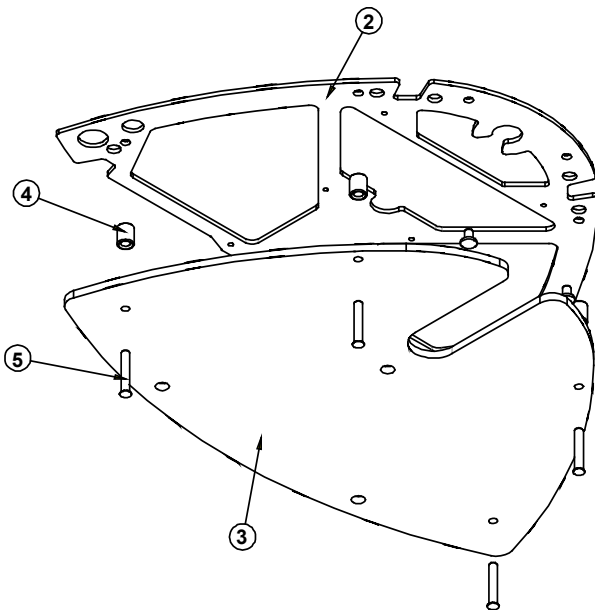
ITEM	DESCRIPTION	SERIAL #	PART #
6	Glass Frame Assembly		7031-015
7	Heat Shield		7031-129
8	Intake Plenum		N/A
9	Latch Assembly, Lower (2)		452-5070
10	Latch Assembly, Upper (2)		7003-006

### Firebox Bottom Assembly

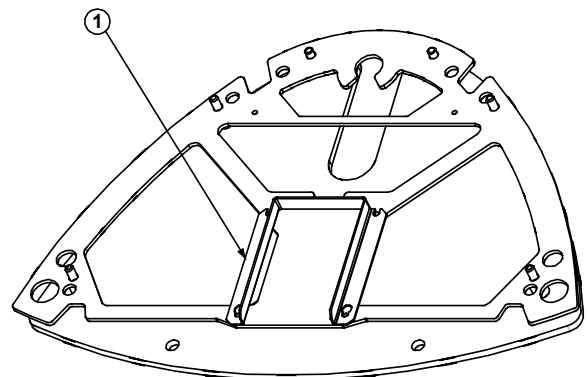


ITEM	DESCRIPTION	SERIAL #	PART #
1	Bulkhead with Flex Tube		7000-156
2	Burner Assembly		7031-032
	Burner Support, One-piece		7031-236
3	Elbow, 3/8 inch		200-0720
4	Firebox Bottom		7031-122
5	Firebox Bottom Gasket		7031-202
	ON/OFF Valve		15697A
	Pilot Assembly, LP		290-013
	Pilot Assembly, NG		2090-012
6	Regulator, LP		LPK-DXV
6	Regulator, NG		NGK-DXV
7	Valve		750-500
	Valve Bracket		7031-128

### Bottom Plate Assembly



ITEM	DESCRIPTION	SERIAL #	PART #
1	Blower Bracket		7031-194
2	Bottom		7031-123
3	Bottom Plate		7031-148
4	Bushing		7000-215
5	Pem Stud		7000-222



**IMPORTANT:** THIS IS DATED INFORMATION. The most current information is located on your dealer's VIP site. When ordering, supply serial and model numbers to ensure correct service parts.

DESCRIPTION	SERIAL #	PART #
Blower with Rheostat		GFK-160A
Front Glass, Bronze		PAL-GLS-BZ
Front Glass, Glacier Blue		PAL-GLS-BL
Front Glass, Green		PAL-GLS-GR
Front Glass, Smoke		PAL-GLS-GY
Gas Conversion Kit - LP to NG		NGK-PALOMA
Gas Conversion Kit - NG to LP		LPK-PALOMA
Rear Vent Conversion Kit		PAL-TR
Remote Control Kit		RCT-MLT-II
Standard Hearth Pad, Bronze		HP-PAL-BZ
Standard Hearth Pad, Glacier Blue		HP-PAL-BL
Standard Hearth Pad, Green		HP-PAL-GR
Standard Hearth Pad, Smoke		HP-PAL-GY
Stone Hearth Pad, Bronze		HP-PALSTN-BZ
Stone Hearth Pad, Glacier Blue		HP-PALSTN-BL
Stone Hearth Pad, Green		HP-PALSTN-GR
Stone Hearth Pad, Smoke		HP-PALSTN-GY
Wall Switch Kit (Off-White)		WSK-21
Wall Switch Kit (White)		WSK-21W
Wall Thermostat		WH-STAT

## G. Warranty Policy

### LIMITED LIFETIME WARRANTY HEAT & GLO GAS APPLIANCE PRODUCTS

**HEAT & GLO**  
Where everything comes together

**BASIC ONE-YEAR WARRANTY.** HEAT & GLO, a brand of HEARTH & HOME TECHNOLOGIES INC., located at 20802 Kensington Boulevard, Lakeville, MN 55044, ("HEAT & GLO") warrants to the original owner that your new HEAT & GLO Gas Appliance (the "Product") will be free from defects in materials and workmanship for a period of one year from the date of installation. During the first year, HEAT & GLO will replace or repair, at its discretion, any defective components at its sole cost and expense, including payment of all reasonable labor costs incurred in replacing or repairing such components. This basic warranty is subject to the conditions, exclusions and limitations described below.

**EXTENDED LIFETIME COVERAGE.** HEAT & GLO warrants that the firebox, heat exchanger, log(s), and burner will not be defective in material or workmanship during the period the Product is owned by the original owner, subject to the following conditions, exclusions and limitations described below.

#### CONDITIONS, EXCLUSIONS AND LIMITATIONS:

1. This warranty applies to the original owner only and is nontransferable.
2. This warranty applies only to Products installed in the United States of America or Canada.
3. This warranty is limited to the replacement or repair of defective components or workmanship and HEAT & GLO may fully discharge all obligations under this warranty by repairing or replacing, at its discretion, the defective components. The maximum amount recoverable under this warranty is limited to the purchase price of the Product and, if HEAT & GLO is unable to provide replacement or repair in an expedient and cost-effective manner, HEAT & GLO may discharge all obligations under this warranty by refunding the purchase price of the Product. IN NO EVENT SHALL HEAT & GLO BE LIABLE FOR ANY INCIDENTAL OR CONSEQUENTIAL DAMAGES CAUSED BY DEFECTS IN THE PRODUCT.
4. Any labor and related repair charges relating to the costs and expenses of replacing or repairing defective components under the Limited Lifetime Warranty are not covered by this warranty, except as provided for under the Basic One-Year Warranty.
5. Components and parts made by other manufacturers, whether sold with the Product or added thereafter, are NOT covered by this warranty unless expressly authorized and approved by HEAT & GLO in writing.
6. Any damages caused by environmental conditions, inadequate ventilation or drafting caused by tight sealing construction of the structure, air handling devices such as exhaust fans or forced air furnaces, or other such causes are not covered by this warranty.
7. This warranty will be void if:
  - a) The Product is not installed, operated and maintained in compliance with local building codes and with the instructions in the Installer's Guide, Owner's Guide and Listing Agent Identification Label furnished with the Product.
  - b) Any parts or components made by other manufacturers are added or used in the Product, unless expressly authorized and approved by HEAT & GLO in writing.
  - c) Any service work is performed on the Product by anyone other than an authorized HEAT & GLO representative.
  - d) The Product is damaged due to shipping, improper handling, accident, abuse or misuse.
  - e) Fuels other than those specified in the Installer's Guide and Owner's Guide are used.
  - f) Modification was made to the Product which was not expressly authorized and approved by HEAT & GLO in writing.

**EXCEPT TO THE EXTENT PROVIDED BY LAW, HEAT & GLO MAKES NO EXPRESS WARRANTIES OTHER THAN THE WARRANTY SPECIFIED HEREIN. THE DURATION OF ANY IMPLIED WARRANTY IS LIMITED TO THE DURATION OF THE WARRANTY SPECIFIED ABOVE.**

Some states do not allow limitations on how long an implied warranty lasts, or do not allow exclusion or limitation of incidental or consequential damages, so those limitations may not apply to you. This warranty gives you specific legal rights, and you may also have other rights which vary from State to State.

If warranty service is needed you should contact your installing dealer and if the installing dealer is unable to provide necessary parts or components, contact the nearest authorized HEAT & GLO dealer or supplier.

#### NOTES TO CUSTOMER:

1. In order to insure proper installation, operation and maintenance HEAT & GLO strongly recommends annual servicing by an authorized HEAT & GLO dealer.
2. Please complete this information and retain this warranty in a safe place for future reference: Installation Date: \_\_\_\_\_  
Model #: \_\_\_\_\_ Serial #: \_\_\_\_\_ Installing Contractor: \_\_\_\_\_
3. HEAT & GLO reserves the right to make changes at any time, without notice, in design, material, specifications and prices of the Product. HEAT & GLO also reserves the right to discontinue styles and products.

H. Contact Information





Where everything comes together

**CONTACT INFORMATION:**

Heat & Glo, a brand of Hearth & Home Technologies, Inc.  
20802 Kensington Boulevard  
Lakeville, MN 55044  
www.heatnglo.com

Please contact your Heat & Glo dealer with any questions or concerns.  
For the number of your nearest Heat & Glo dealer,  
please call 1-888-427-3973

	<b>CAUTION</b>
	Do NOT discard this manual. <ul style="list-style-type: none"><li>• Important operating and maintenance instructions included.</li><li>• Read, understand and follow these instructions for safe installation and operation.</li><li>• Leave this manual with party responsible for use and operation.</li></ul>



**Your Records for Model:  
Paloma Direct Vent Gas Appliance**

SERIAL NUMBER: \_\_\_\_\_

DATE PURCHASED: \_\_\_\_\_

DATE INSTALLED: \_\_\_\_\_

DEALERSHIP WHERE PURCHASED: \_\_\_\_\_

DEALER TELEPHONE: \_\_\_\_\_

This product may be covered by one or more of the following patents: (United States) 4593510, 4686807, 4766876, 4793322, 4811534, 5000162, 5016609, 5076254, 5113843, 5191877, 5218953, 5263471, 5328356, 5341794, 5347983, 5429495, 5452708, 5542407, 5601073, 5613487, 5647340, 5688568, 5762062, 5775408, 5890485, 5931661, 5941237, 5947112, 5996575, 6006743, 6019099, 6048195, 6053165, 6145502, 6170481, 6237588, 6296474, 6374822, 6413079, 6439226, 6484712, 6543698, 6550687, 6601579, 6672860, 6688302B2, 6715724B2, 6729551, 6736133, 6748940, 6748942, D320652, D445174, D462436; (Canada) 1297749, 2195264, 2225408; or other U.S. and foreign patents pending.

